

Applicable to Type-C Interface, 30V OVP, 1.5A , with NTC and Enabling Function, 2-3 Multi Specification Lithium Battery Boost Charger

General Description

The IU5099E is a 5V input, 1.5A maximum charging current, boost charging management IC that supports 2-3 lithium-ion batteries/lithium iron phosphate series applications. IU5099E integrates power MOS and adopts asynchronous switch architecture, so that it only needs a few peripheral devices in application, which can effectively reduce the overall scheme size and BOM cost. The working frequency of the boost switch charging converter of IU5099E is 500KHz, and the conversion efficiency is 90%.

The IU5099E has four built-in loops to control the charging process, including constant current (CC) loop, constant voltage (CV) loop, chip temperature regulation loop, and intelligently adjust the charging current to prevent the adapter output from collapsing, and to match the input adaptive loop of all adapters.

The IU5099E integrates the 30V OVP function. The input port can stably and reliably withstand the withstand voltage impact within 30V, and stop charging when the input exceeds 6V. It is very suitable for the application of type-C interface. At the same time, the chip bat output port withstands 30V, which greatly improves the reliability of the system.

IU5099E provides e-MSOP10 package type for customers to choose, and its rated working temperature range is -40 °C to 85 °C.

Features

- USB 5V Input Asynchronous Switch Boost Charging
- Operation Voltage is 3.6~6V, 30V Withstand Voltage, Internal Integrated High Voltage Transistor
- Maximum 1.5A Charging Current, External Resistance of Charging Current is Adjustable
- NTC Function, Reuse with Enabling Function
- Input Current Adaptive Function, Matching All Adapters
- The Constant Voltage Charging Voltage is Independently Adjustable, Suitable for Lithium Batteries of Different Specifications
- Support Led Charging Status Indication
- 500KHz Switching Frequency
- Output Overvoltage and Short Circuit Protection
- Integrated 30V OVP Function
- IC Over Temperature Protection
- IC Temperature Adaptive Adjustment Function
- Good EMI Characteristics

Applications

- POS Machine
- Bluetooth Speakers
- Toys
- 4.2V/4.3V/4.35V/4.4V Lithium Battery Pack
- Interphone
- Lithium Iron Phosphate Battery Pack

Package

- e-MSOP10

Typical Applications

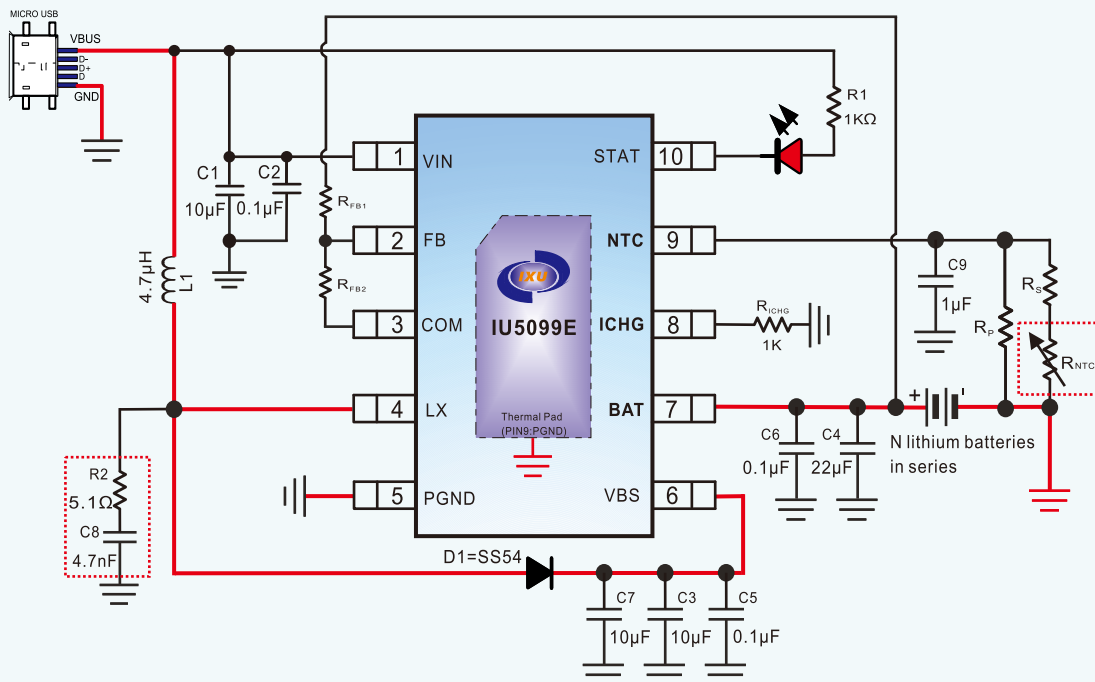

IU5099E Application Circuit

Note:

- (1) L1 is the power inductance with a saturation current of 5A; SS54 is a low-voltage drop Schottky diode.
- (2) All chip capacitors should be arranged as close to the chip pin as possible.
- (3) The 9th pin of the chip, namely the NTC pin, can be reused as an enable pin. When it is set to zero potential, chip charging is prohibited. The pin cannot float. If the NTC function is not used or the NTC resistance of the battery is not connected during production test, the pin must be connected to the ground with a total resistance of 47KΩ.
- (4) In order to further improve EMI characteristics, it is necessary to add a microwave absorbing network composed of R2 and C8.
- (5) The setting value of constant current charging current must be greater than 500mA, that is, richg must be less than 2KΩ.
- (6) When the battery end needs hot plug operation, or is connected to inductive loads such as motors, it is recommended to add another capacitor of at least 100 μF next to C4 to further improve reliability.
- (7) The 10th pin of the chip, namely the stat pin, is an output pin of open drain od structure, which outputs 0 level or high resistance state.
- (8) It is recommended to add a 1KΩ resistor to the ground at the first pin of the chip to eliminate the phenomenon that the voltage at the first pin may not be 0 when the input power is unplugged due to the reverse leakage current of the Schottky diode itself.
- (9) The solid red line in the figure shows the path of high current flow.

PIN Configuration and Functions

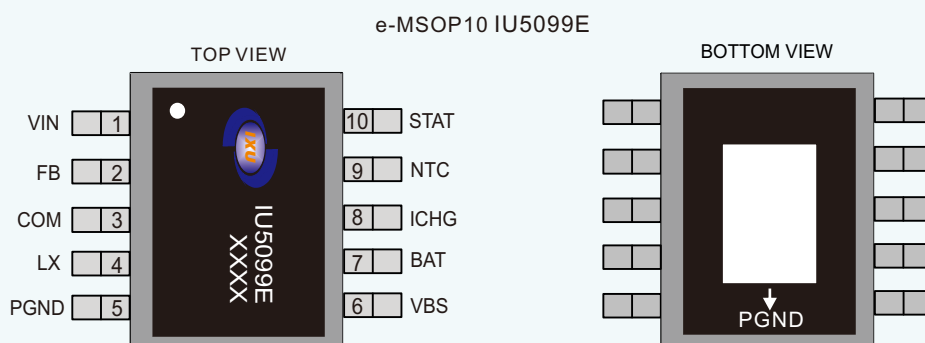

IU5099E PIN	NAME	TYPE	DESCRIPTION
1	VIN	P	Analog power input pin.
2	FB	I	Battery voltage feedback terminal.
3	COM	O	Battery voltage detection resistance and chip internal switch tube connection terminal
4	LX	I	Switch node pin, connect to external inductor.
5	PGND	-	Power ground pin.
6	VBS	O	Boost output pin.
7	BAT	P	Battery positive pin.
8	ICHG	I	Charge current program pin, pull down to GND with a resistor can change the value of charging current.
9	NTC	O	Thermistor input pin, through the external thermistor to detect the battery temperature. And can be multiplexed as an enable port.
10	STAT	O	Charge status indication pin: output 0 level or high resistance state.
Thermal PAD	PGND	-	Power ground pin.

Functional Block Diagram

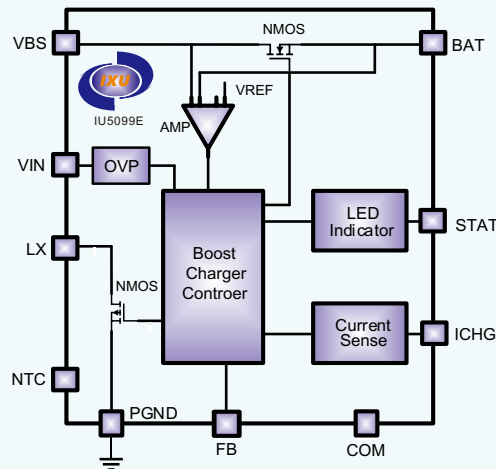

Absolute Maximum Ratings ¹

SYMBOL	PARAMETER	VALUE	UNIT
VMAX	VIN, BAT, LX, VBS, STAT, NTC, FB, COM	-0.3~30	V
	ICHG	-0.3~6	V
T _J	Junction operating temperature range	-40~150	°C
T _{STG}	Storage temperature range	-55~150	°C
T _{SDR}	Lead temperature (Soldering, 10 sec.)	260	°C

Recommended Operating Conditions

SYMBOL	PARAMETER	VALUE	UNIT
VIN	Input voltage	3.6~6	V
T _J	Junction operating temperature range	-40~125	°C
T _A	Ambient temperature range	-40~85	°C

Thermal Information ²

SYMBOL	PARAMETER	VALUE	UNIT
θ _{JA}	Package thermal resistance - chip to environment thermal resistance	40	°C/W

Ordering Information

Device	Package	Making	Reel Size	Tape Width	Quantity
IU5099E	e-MSOP10		13"	12mm	5000 units

ESD Range

HBM (Human Body Model) ----- ±2kV

MM (Machine model) ----- ±200V

1. The above parameters are only the limit values of device operation. It is not recommended that the working conditions of the device exceed the limit values. Otherwise, the reliability and life of the device will be affected, and even permanent damage will be caused.

2. Where the PCB board is placed in IU5099E, a heat dissipation design is needed. The heat sink at the bottom of IU5099E is connected with the heat sink area of PCB board.



Electrical Characteristics ($V_{IN}=5V$, $R_{ICHG}=1K\Omega$, $L=4.7\mu H$, unless otherwise specified)

SYMBOL	PARAMETER	TEST CONDITIONS	MIN	TYP	MAX	UNIT
V_{IN}	VIN Supply voltage		3.6	5	6	V
$V_{IN_{OVP}}$	VIN over voltage protection	VIN rising		6		V
$\Delta V_{IN_{OVP}}$	VIN over voltage protection hysteresis			200		mV
I_Q	VIN Input quiescent current			0.6		mA
I_{SD}	VIN Input turned off current	$V_{NTC}=0V$		200		μA
I_{BAT}	Battery leakage current	Charging complete, $R_{FB1}=1.2M\Omega$, $R_{FB2}=200K\Omega$		25		μA
		$V_{IN}=0V$ or $V_{NTC}=0$		5		
V_{FB}	Feedback voltage regulation threshold		1.118	1.2	1.212	V
V_{CV}	Terminal battery voltage	$K=1+R_{FB1}/R_{FB2}$		$K \cdot V_{FB}$		V
V_{RCH}	Recharge voltage threshold	V_{BAT} Falling		$0.98V_{FB}$		mV
V_{TRK}	TC charge mode battery voltage threshold	V_{BAT} Rising		$0.67V_{CV}$		V
V_{SHORT}	Battery short threshold	V_{BAT} Falling		$0.17V_{CV}$		V
V_{OVPB}	BAT over voltage threshold	V_{BAT} Rising		$1.1V_{CV}$		V
I_{CC}	CC charge mode current	$R_{ICHG}=1K\Omega$	0.9	1	1.1	A
I_{TC}	TC charge mode current			10%		I_{CC}
I_{BS}	Output short circuit charge mode current			10%		I_{CC}
I_{BF}	Terminate charge current			10%		I_{CC}
F_{SW}	Switching frequency			500		KHz
A_I	CC charge mode current gain	$A_I=I_{CC}/I_{ICHG}$		1000		



Electrical Characteristics ($V_{IN}=5V$, $R_{ICHG}=1K\Omega$, $L=4.7\mu H$, unless otherwise specified)

SYMBOL	PARAMETER	TEST CONDITIONS	MIN	TYP	MAX	UNIT
I_{NTC}	NTC PIN output current		18	20	22	μA
V_{NTCL}	NTC low temp threshold	V_{NTC} rising		1.31		V
V_{NTCH}	NTC high temp threshold	V_{NTC} falling		0.4		V
T_{REG}	Chip thermal regulation threshold			120		$^{\circ}C$
T_{SD}	Thermal shutdown temperature			150		$^{\circ}C$
ΔT	Thermal shutdown temperature hysteresis			20		$^{\circ}C$
TMR_{TC}	Trick charge time limit			9.5		Hour
$TMR_{CC/CV}$	CC/CV charge time limit			15.5		Hour

IU5099E Application Points

1. Charge Process

IU5099E adopts complete CC/CV charging mode. When the battery voltage is less than the set trickle point, the system will charge the battery with trickle current. When the battery voltage is greater than the set trickle point, the system enters the constant current charging mode. When the battery voltage approaches the set floating charge voltage, the system enters the constant voltage mode. When the system enters the constant voltage mode, if the charging current is less than the termination charging current, the system will stop charging, indicating that the battery is fully charged. If the battery voltage drops below the restart voltage, the system will restart to charge the battery. The so-called charging current ICC here refers to the current value flowing from the chip bat port to the battery positive pole.

2. Protection Function

IU5099E has perfect battery charging protection function. When the chip has over voltage at the input end, over voltage at the output end and over temperature of the chip, the boost charging function will be turned off immediately. When the battery voltage is lower than V_{SHORT} , the output undervoltage protection function is turned on, the main power tube is turned off first, and the block tube will enter the linear mode and charge the battery with a small short-circuit mode charging current; When the battery voltage is higher than V_{SHORT} , the output short-circuit protection function is turned off.

3. Adaptive Input Current Limit Function

The IU5099E has a special built-in loop, which can automatically adjust the size of the charging current, so as to avoid the input DC power supply entering the overdrive state. Because the large charging current will lead to the decline of the input power supply voltage, with the decline of the power supply voltage, the input of the internal adaptive loop op amp will also decline. When it is reduced to the internal reference value, the built-in adaptive loop will automatically adjust the duty cycle of the system, reduce the charging current and the driving pressure of the input power supply, so that the input voltage is fixed at about 4.235V.

4. Chip Temperature Adaptive Adjustment Function

IU5099E has a built-in temperature control loop. When the chip is in the constant current charging process, if the temperature rises to 120°C, the temperature control loop will start to work. The charging current will gradually decrease, and the chip temperature will decrease. Finally, the chip temperature will stabilize at the set value, thus protecting the chip.

5. Charging LED Indication

The stat state pin of the chip outputs level 0 or high resistance state. If the LED lamp is not connected, but is directly connected to the master control, there must be a pull-up resistor to convert the high resistance state to the exact high level.

- It is always on during charging and extinguished after being fully charged.
- When the battery terminal overvoltage, battery short circuit, charging time timeout, chip overheating, NTC port detects abnormal battery temperature, input overvoltage and other conditions occur, it flashes at a frequency of 1.6Hz.

6. NTC Resistance Setting

The IU5099E supports the NTC protection function when charging the battery, and detects the battery temperature through the NTC pin. When the detection temperature exceeds the set temperature window value, the system will stop charging.

The working mode of NTC protection function is: the NTC pin is externally connected to the resistance network to GND, and a constant 20μA current is output from the NTC pin. The temperature range of the battery is determined by the voltage drop generated by the current on the resistance network. The internal judgment point of low temperature is 1.31V, and the internal judgment point of high temperature is 0.4V. As shown in the figure, the resistance network composed of R_p and R_s can be designed with appropriate NTC resistance. The NTC pin cannot float. If the NTC function is not used or the NTC resistance of the battery is not connected during the production test, the pin must be connected to the ground with a total resistance of 47KΩ.

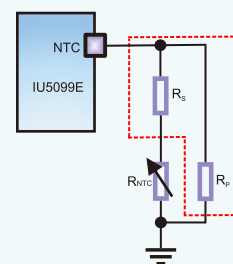

7. Enable Function

The NTC pin can be reused as a chip enable pin. When the NTC pin voltage is connected to the zero level (the maximum is not more than 0.2V), the chip charging is prohibited, and the STAT pin outputs the high resistance state at the same time.

8. ICHG Resistor R_{ICHG}

The value of the ICHG terminal resistance reflects the size of the charging current. According to different applications, the size of the charging current can be easily determined by adjusting the value of the ICHG terminal resistance R_{ICHG} (R_{ICHG} must be less than 2KΩ). The specific circuit is shown in the following figure:

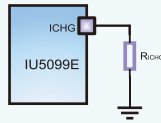

The relationship between I_{CC} and R_{ICHG} during constant current charging is determined by the following formula:

$$I_{CC} = \frac{1 * 1000}{R_{ICHG}}$$

9. Battery Floating Charge Voltage Setting

The internal clamping voltage threshold corresponding

to the chip FB pin is 1.2V. According to this voltage and the two external voltage dividing resistors R_{FB1} and R_{FB2} , the floating charge voltage value of battery charging can be set. The specific formula is as follows:

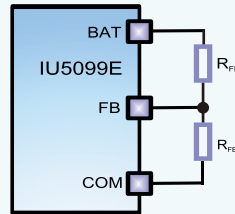

$$V_{CV} = \frac{1.2 * (R_{FB1} + R_{FB2})}{R_{FB2}}$$

Precautions for IU5099E PCB

The PCB shown in our demo is only one example of chip application, which does not mean that customers must layout their products completely according to the above figure. Please make layout and wiring according to the actual components and product requirements. However, the layout principles and matters needing attention shown in the right figure are universal for each product.

- The inductance wiring should be as wide as possible, and separate wiring should supply power for the chip.
- The main current circuit wiring of boost module should be short and thick.
- LX routing should be as short as possible, and it should not cover excess area as much as possible to optimize EMI.
- The inductor and Schottky diode shall be directly connected, and the connection shall be short and thick to avoid through-hole jumper.
- The capacitance of the power supply should be placed as close to the chip pin as possible.
- The heat sink at the bottom of the chip is power ground, which should be connected with a large piece of ground and reliably welded.

Package Information

IU5099E e-MSOP10 PACKAGE OUTLINE DIMENSIONS (units:mm)

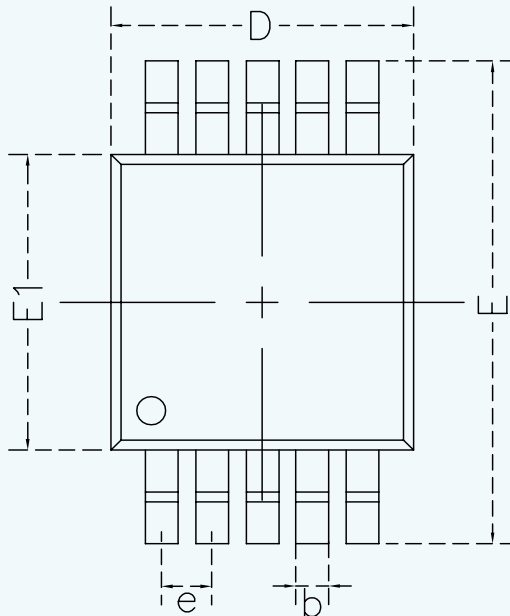

TOP VIEW

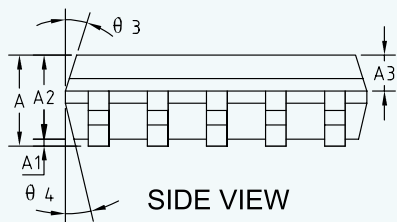

SIDE VIEW

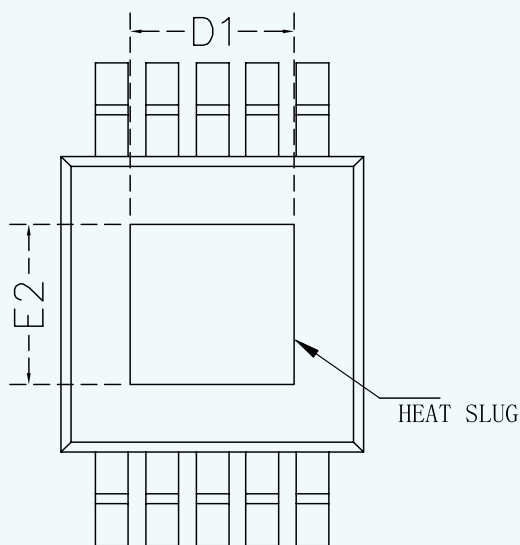

BOTTOM VIEW

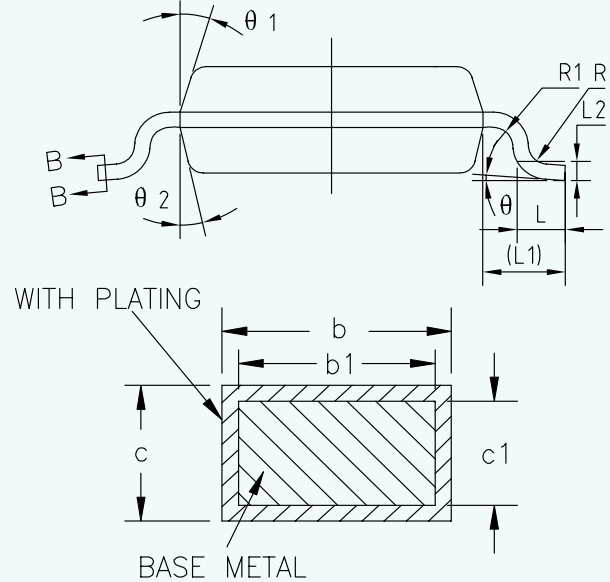

SYMBOL	MIN	NOM	MAX
A	—	—	1.10
A1	0	—	0.15
A2	0.75	0.85	0.95
A3	0.25	0.35	0.39
b	0.28	0.325	0.37
b1	0.27	0.30	0.33
c	0.154	0.177	0.20
c1	0.144	0.152	0.16
D	2.90	3.00	3.10
e	0.40	0.50	0.60
E	4.70	4.90	5.10
E1	2.90	3.00	3.10
D1	0.75	1.625	2.5
E2	0.75	1.625	2.5
L	0.40	0.60	0.80
L1	0.95REF		
L2	0.25BSC		
R	0.07	—	—
R1	0.07	—	—
θ	0°	—	8°
$\theta 1$	9°	12°	15°
$\theta 2$	9°	12°	15°
$\theta 3$	9°	12°	15°
$\theta 4$	9°	12°	15°

NOTES:
 1. ALL DIMENSIONS REFER TO JEDEC STANDARD MO-137E
 2. DIMENSION D DOES NOT INCLUDE MOLD FLASH
 3. DIMENSION E1 DOES NOT INCLUDE MOLD FLASH
 4. FLASH OR PROTRUSION SHALL NOT EXCEED 0.25mm PER SIDE.

TAPE AND REEL INFORMATION

REEL DIMENSIONS

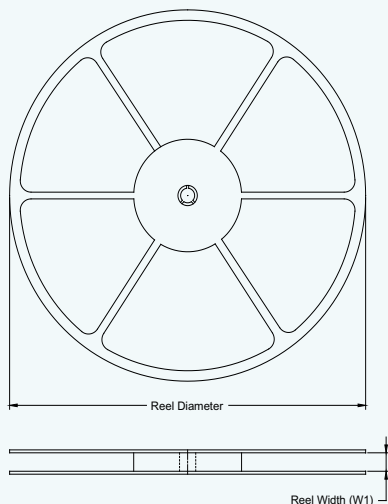

TAPE DIMENSIONS

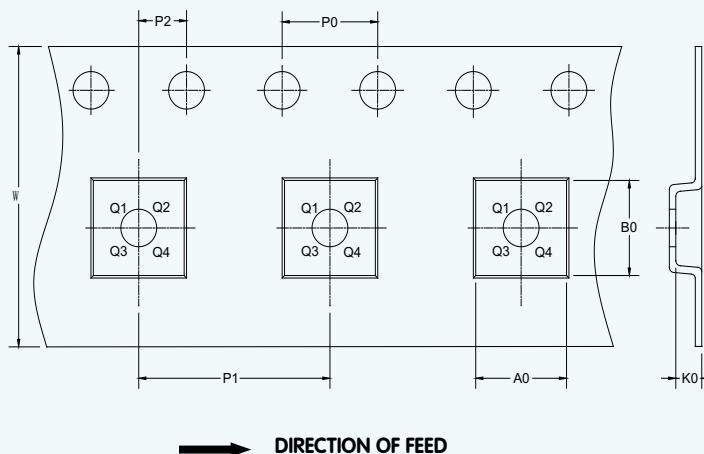

NOTE: The picture is only for reference. Please make the object as the standard.

KEY PARAMETER LIST OF TAPE AND REEL

Package Type	Reel Diameter	Reel Width W1 (mm)	A0 (mm)	B0 (mm)	K0 (mm)	P0 (mm)	P1 (mm)	P2 (mm)	W (mm)	Pin1 Quadrant
e-MSOP-10 (Exposed Pad)	13"	12	5.20	3.30	1.50	4.0	8.0	2.0	12.0	Q1