

## Low No-Load Current, AM Suppression Function, 155W Mono Class D Audio Power Amplifier

### General Description

CS8683H is a 155W mono sound class D audio amplifier; The device is designed with a heat dissipation pad at the top level. After connecting the radiator to the pad, it can achieve continuous power output of more than 155W, and can drive loads as low as 2Ω under appropriate power supply voltage; CS8683H has advanced EMI suppression technology. It adopts surface mount technology. With only a small number of peripheral devices, the system has high-quality audio output power. CS8683H has built-in overcurrent protection, short circuit protection and overheating protection, which can effectively protect the chip from damage under abnormal working conditions. CS8683H can achieve a maximum efficiency of more than 92%. The withstand voltage design of more than 45V provides ultra-high reliability for the chip, which can effectively reduce the proportion of defects in the production process. CS8683H provides a special EQB32 package form for customers to choose. The appropriate package size provides the greatest convenience for customers to install radiator parts. Its rated working temperature range is - 40 °C to 85 °C.

### Package

- EQB32

### Features

- Output Power (THD+N=10%)  
VCC = 24V@RL = 4 Ω 75W;  
@RL = 2 Ω 145W(Transient)  
VCC = 28V@RL = 4 Ω 112W;  
@RL = 3 Ω 145W(Transient)  
VCC = 32V@RL = 4 Ω 145W  
VCC = 34V@RL = 4 Ω 155W  
VCC = 36V@RL = 8 Ω 99W
- Single Power Supply, Wide Power Supply Voltage Range:5V~36V
- High Reliability Design: 45V Withstand Voltage Design
- Efficiency: 92%@PV<sub>CC</sub>=15V PO=20W
- Three Stage Gain Optional
- Mute Function Control
- Audio System with Filter Network, Quiescent Current 15mA@24V
- Multiple Switching Frequency Optional: AM Suppression Function
- The Output Pin is Convenient for Wiring Layout
- Good Short Circuit Protection and Temperature Protection with Automatic Recovery Function
- Good Distortion and Anti Pop Function
- Differential Input
- Enhanced Packaging Design: Special Design of Top Heat Sink
- Meet The Application Requirements of Auto Mobile

### Applications

- Car Audio
- Home Audio System
- Emergency Call

### Typical Applications

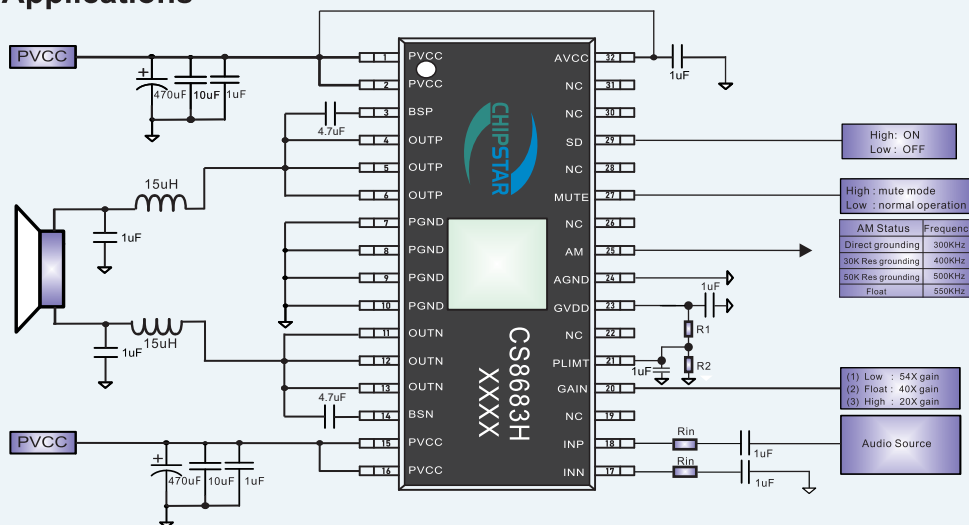

NOTE:

- It is recommended to select the output inductance with saturation current above 6A.
- The gain terminal is grounded, integrating 12K input resistance and 650K feedback resistance.
- The gain terminal is suspended, integrating 15.2k input resistance and 610K feedback resistance.
- The gain terminal is terminated at high level, integrating 25.5K input resistance and 510K feedback resistance.

## PIN Configuration and Functions

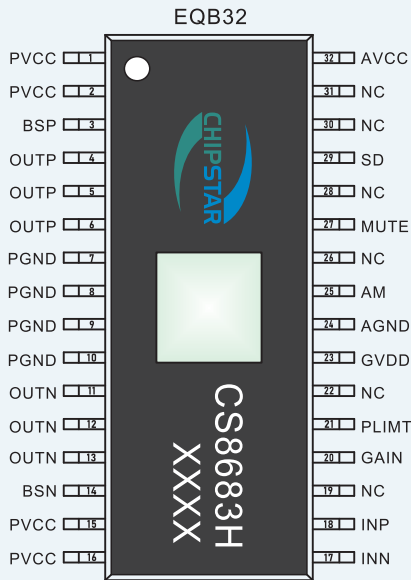

PIN	NAME	I/O	DESCRIPTION
1,2	PVCC	P	Power supply
3	BSP	I	Positive output upper tube bootstrap
4,5,6	OUTP	O	Audio output positive terminal
7,8,9,10	PGND	P	Power ground
11,12,13	OUTN	O	Audio output negative terminal
14	BSN	I	Negative output upper tube bootstrap
15,16	PVCC	P	Power supply
17	INN	I	Audio input negative terminal
18	INP	I	Audio input positive terminal
19,22,26	NC	P	NC
20	GAIN	I	Gain control pin
21	PLIMIT	I	Output power limit pin
23	GVDD	I	Upper gate drive voltage
24	AGND	I	Analog ground
25	AM	I	AM frequency control pin
26,28,30,31	NC	P	NC
27	MUTE	I	Mute mode control pin
29	SD	P	Turn off the control pin
32	AVCC	P	Analog power supply

**NOTE:**

- The above figure is a top view
- The white box in the figure is the top heat sink

## Functional Block Diagram

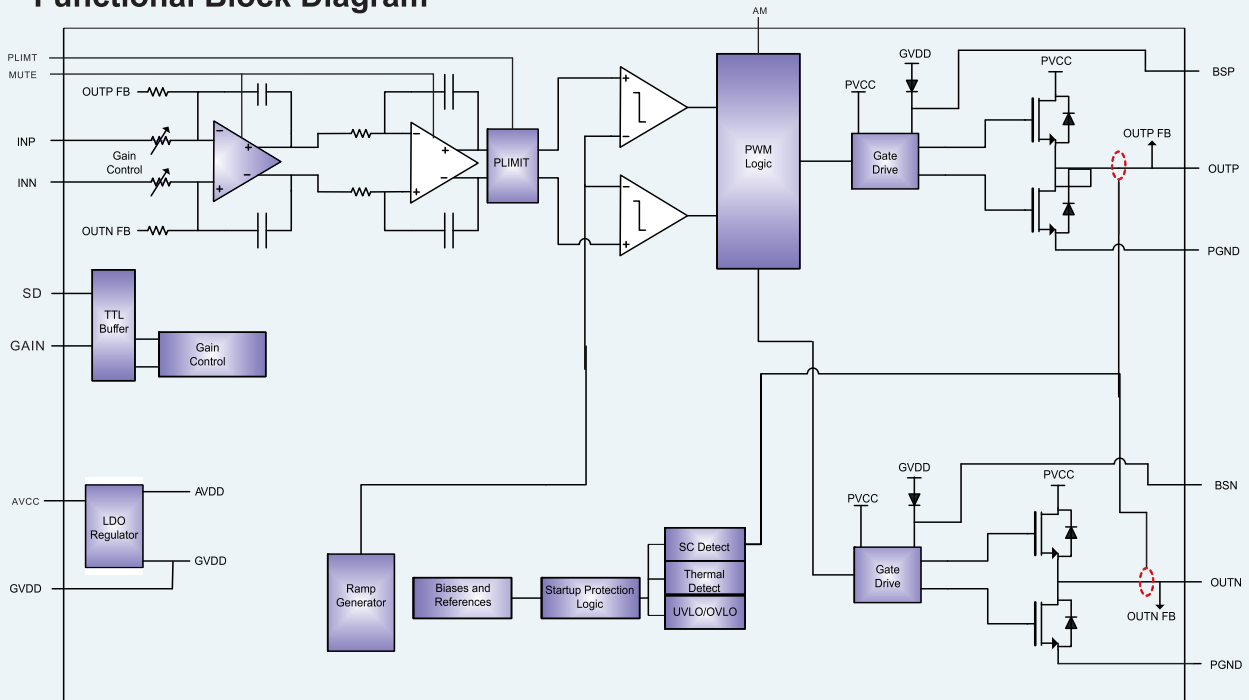

### Absolute Maximum Ratings <sup>1</sup>

SYMBOL	PARAMETER	PIN	VALUE	UNIT
V <sub>CC</sub>	Power supply	PVCC	-0.3 to 45	V
V <sub>i</sub>	Input voltage	SD	-0.3 to 45	V
		GAIN,PLIMIT,AM,MUTE	-0.3 to 6.0	V
		INN,INP	-0.3 to 6.0	V
T <sub>A</sub>	Ambient temperature range		-40~85	
T <sub>J</sub>	Junction operating temperature range		-40~150	°C
T <sub>STG</sub>	Storage temperature range		-40~150	°C

### Recommended Operating Environment

SYMBOL	PARAMETER	VALUE	UNIT
PV <sub>CC</sub>	Input power supply voltage	5~36	V
T <sub>J</sub>	Junction operating temperature range	-40~125	°C
T <sub>A</sub>	Ambient temperature range	-40~85	°C

### Thermal Information

SYMBOL	PARAMETER	VALUE	UNIT
θ <sub>JA</sub>	Package thermal resistance - chip to environment thermal resistance	25	°C/W
θ <sub>JC</sub>	Package thermal resistance - chip to package surface thermal resistance	7	°C/W

### Ordering Information

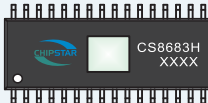
Product Name	Package Type	Device Marking	Reel Size (Inch)	Tape width	Quantity
CS8683H	EQB32		Tube		20

### ESD Range

HBM (Human Body Model) ----- ±2kV  
 MM (Machine model) ----- ±200V

1. The above parameters are only the limit values of device operation. It is not recommended that the working conditions of the device exceed the limit values. Otherwise, the reliability and life of the device will be affected, and even permanent damage will be caused.

### Recommended Operating Conditions

DESCRIPTION	TEST CONDITIONS	MIN	MAX	UNIT
V <sub>CC</sub> Power supply	PVCC	5	36	V
V <sub>IH</sub> Input high level	SD,MUTE,AM,PLIMIT,GAIN	2		V
V <sub>IL</sub> Input low level	SD,MUTE,AM,PLIMIT,GAIN		0.8	V
I <sub>IH</sub> High level input current	SD,MUTE,AM,PLIMIT,GAIN,V <sub>I</sub> =2V,V <sub>CC</sub> =20V		50	uA
I <sub>IL</sub> Low level input current	SD,MUTE,AM,PLIMIT,GAIN,V <sub>I</sub> =0.2V,V <sub>CC</sub> =20V		5	uA
OVP Overvoltage protection			45	V

### DC Parameters

DESCRIPTION	TEST CONDITIONS	MIN	TYP	MAX	UNIT
V <sub>OS</sub>   Output offset voltage	V <sub>IN</sub> =0V , GAIN=36dB		6	15	mV
I <sub>CC</sub> Quiescent current	SD=2V,4Ω loudspeaker ,PV <sub>CC</sub> =18V		15	18	mA
I <sub>CC(SD)</sub> Standby current	SD=0V,No load and filtering,PV <sub>CC</sub> =24V		50	300	uA
r <sub>DS(on)</sub> Drain source on resistance	V <sub>CC</sub> =21V,I <sub>O</sub> =500mA, T <sub>J</sub> =25°C				
	Upper tube		100		mΩ
	Lower tube		100		mΩ
t <sub>on</sub> Turn on time	SD=2V		210		ms
t <sub>OFF</sub> Turn off time	SD=0V		2		us
GVDD Gate drive voltage	I <sub>GVDD</sub> =100 mA	4.25	4.75	5.25	V
V <sub>O</sub> Maximum output voltage under power limitation	V(PLIMIT) = 2V; V <sub>I</sub> = 1Vrms		6.5		V
f <sub>osc</sub> Oscillation frequency	AM Direct grounding	270	300	330	kHz
	AM Grounded through 30K resistance	360	400	440	
	AM Grounded through 50K resistance	450	500	550	
	AM Float	500	550	600	

### AC Parameters

DESCRIPTION	TEST CONDITIONS	MIN	TYP	MAX	UNIT
K <sub>SVR</sub> Power ripple rejection ratio	1kHz, 200mVpp Ripple, Gain=20dB, Input AC coupled to ground		70		dB
THD+N Total harmonic distortion + noise	PVCC=24V , f=1kHz, P <sub>O</sub> =20W		0.05		%
Output noise	20~22kHz , Aweight , Gain=20dB		100		uV
			-78		dBV
Efficiency	PVCC= 15V, f= 1kHz, P <sub>O</sub> =20W		92		%
SNR Signal to noise ratio	Maximum output at gain = 20dB , THD+N < 1% , f=1kHz		102		dB
Thermal protection temperature			170		°C
Hysteresis temperature			15		°C
P <sub>O</sub> Output power	VDD = 22V@RL = 2 Ω	THD+N=10%@PO=124W	THD+N=1%@PO=100W		
	VDD = 24V@RL = 4 Ω	THD+N=10%@PO=75W	THD+N=1%@PO=60W		
	VDD = 24V@RL = 2 Ω	THD+N=10%@PO=145W	THD+N=1%@PO=113W		
	VDD = 28V@RL = 4 Ω	THD+N=10%@PO=112W	THD+N=1%@PO=92W		
	VDD = 28V@RL = 3 Ω	THD+N=10%@PO=145W	THD+N=1%@PO=118W		
	VDD = 30V@RL = 4 Ω	THD+N=10%@PO=130W	THD+N=1%@PO=106W		
	VDD = 34V@RL = 4 Ω	THD+N=10%@PO=155W	THD+N=1%@PO=126W		
	VDD = 36V@RL = 8 Ω	THD+N=10%@PO=99W	THD+N=1%@PO=80W		

**Typical Characteristics** All tests are based on 1kHz signal (unless otherwise specified)

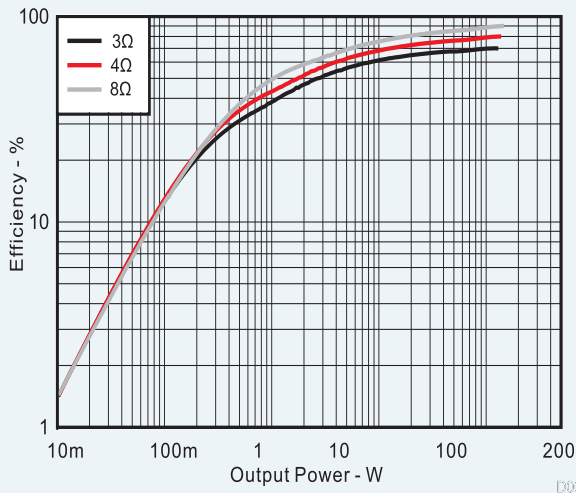
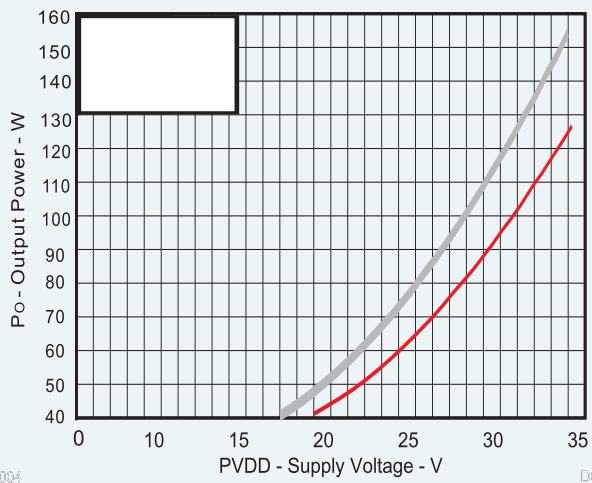
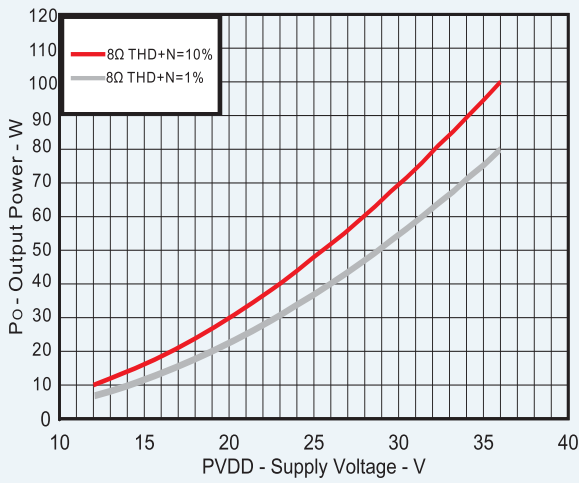
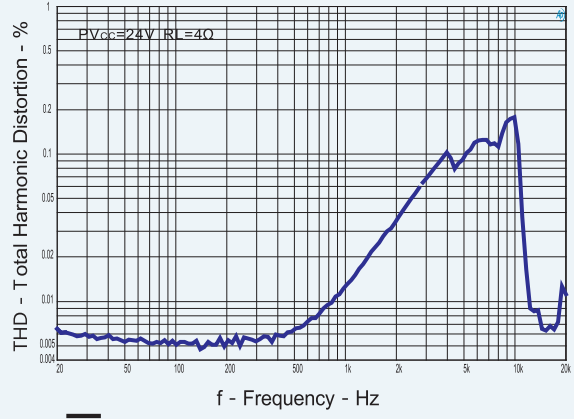
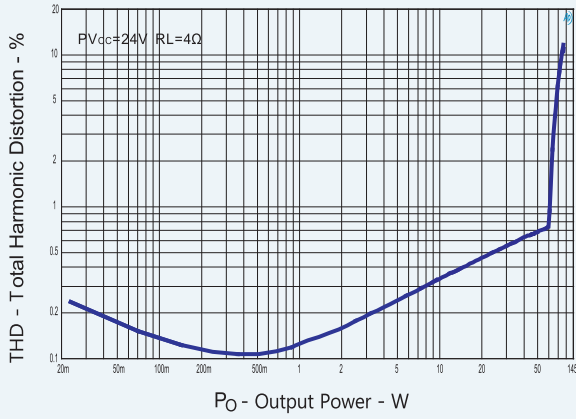

**Efficiency vs Output Power**

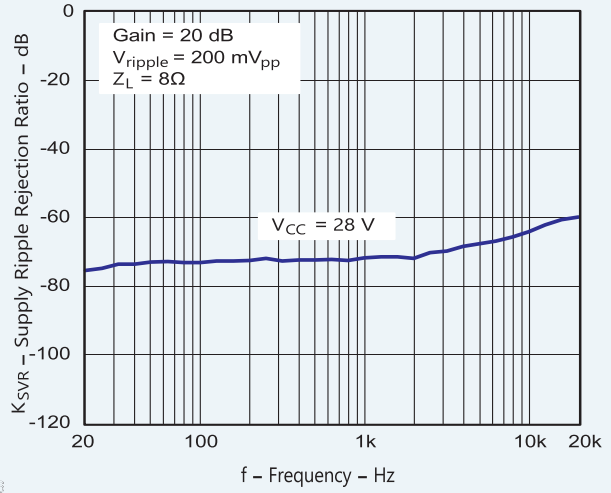

**SUPPLY RIPPLE REJECTION RATIO vs FREQUENCY**

## CS8683H Application Points

### 1. Overview

CS8683H is a 155W mono sound class D audio amplifier; The device is designed with a heat dissipation pad at the top level. After connecting the radiator to the pad, it can achieve continuous power output of more than 155W, and can drive a load as low as 2Ω under the applicable power supply voltage; CS8683H has advanced EMI suppression technology. It adopts surface mount technology. With only a small number of peripheral devices, the system has high-quality audio output power. CS8683H has built-in overcurrent protection, short circuit protection and overheating protection, which can effectively protect the chip from damage under abnormal working conditions. CS8683H can achieve a maximum efficiency of more than 92%. The withstand voltage design of more than 45V provides ultra-high reliability for the chip, which can effectively reduce the proportion of defects in the production process.

### 2. Gain Setting

CS8683H is set with gain control pin gain. The following table shows the gain control mode of CS8683H and the corresponding integrated input and feedback resistance values.

GAIN State	Magnification	Input Res	Feedback Res
LOW	54X	12K	650K
FLOAT	40X	15.2K	610K
HIGH	20X	25.5K	510K

### 3. Short Circuit Protection and Automatic Recovery

CS8683H protects the overcurrent state caused by short circuit at the output end. In case of short circuit, CS8683H immediately closes the output. After the short circuit fault at the output end is eliminated, CS8683H only needs to wait 110ms to recover itself.

### 4. Temperature Protection

The temperature protection of CS8683H is to prevent device damage when the temperature exceeds 170°C. There is an upper and lower allowable range of ± 15°C between devices at this temperature point. Once the temperature exceeds the set temperature point, the device enters the closed state without output. When the temperature drops by 20°C, the temperature protection will be eliminated and the device starts to work normally.

### 5. Mute Function and Shutdown Control

When the CS8683H works normally, the SD input port should be high potential. When the SD is pulled to the low potential, the output is turned off, the circuit enters the standby mode, and the SD terminal can be connected to PVCC at most. The mute input port should be low potential when the CS8683H works normally. When the mute is pulled to the high potential, the CS8683H output stage is turned off, the CS8683H

enters the mute mode, and the maximum withstand voltage of the mute terminal is 6V.

### 6. AM Suppression Function

CS8683H realizes the selection of MOS switching frequency through the control of AM pin, as shown in the table below:

AM Status	Frequency
Direct grounding	300KHz
30K Res grounding	400KHz
50K Res grounding	500KHz
Float	550KHz

### 7. Power Limit

The principle of power limiting function is to limit the maximum duty cycle of power amplifier output PWM, so as to limit the maximum output power. The user can control the value of the maximum duty cycle by setting the voltage on the PLIMIT pin, so as to determine the set value of the maximum power. The result obtained by the power limiting method of limiting the maximum duty cycle is the same as reducing the PVCC supply voltage, and the output waveform is the clipping waveform with distortion, as shown in the figure. When the power is limited, if the input analog signal is further increased, the distortion of the output waveform will increase and the power will rise slowly. A voltage dividing resistor can be added between GVDD and the ground to set the voltage of pin 21 (PLIMIT) to limit the output power. The higher the voltage of pin 21, the greater the allowable output power. Add a 1uF capacitor from pin 21 to the ground.

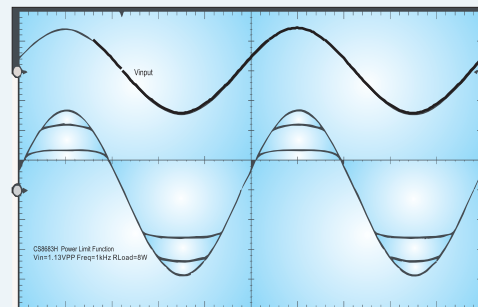

CS8683H power limit waveform

### 8. Inductance and Capacitance

CS8683H needs to load inductor and filter capacitor at the output end. It is recommended that the inductance should reach a saturation current of more than 6A during use. The specific parameters are shown in the figure below:

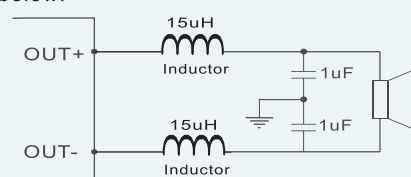

### 9. CS8683H PCB Design Guide

In order to provide reliable performance of the audio system, please pay special attention to the following points when designing the pcb layout of CS8683H:

The high current path of the chip is: Vin → chip PVCC → GND. The routing rule of high current path is as thick as possible to reduce the impedance caused by PCB routing.

The power supply pin of CS8683H must be pasted with two ceramic capacitors 10uF and 1uF, and be as close to the chip pin as possible. 470uF/50V is recommended for power supply electrolytic capacitor.

All GND, including the GND of each capacitor, should be well connected, which can be connected with the copper foil of large area GND nearby, so as to reduce the ground loop impedance and inductive reactance as much as possible.

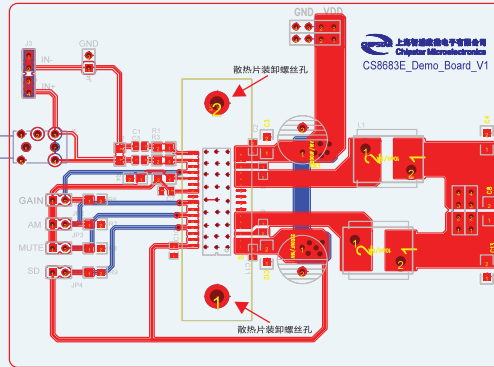

### Description of Heat Sink of Demo

The heat sink used on the EVB of CS8683H is a 14mm × 25mm × 50mm aluminum radiator with the following dimensions:

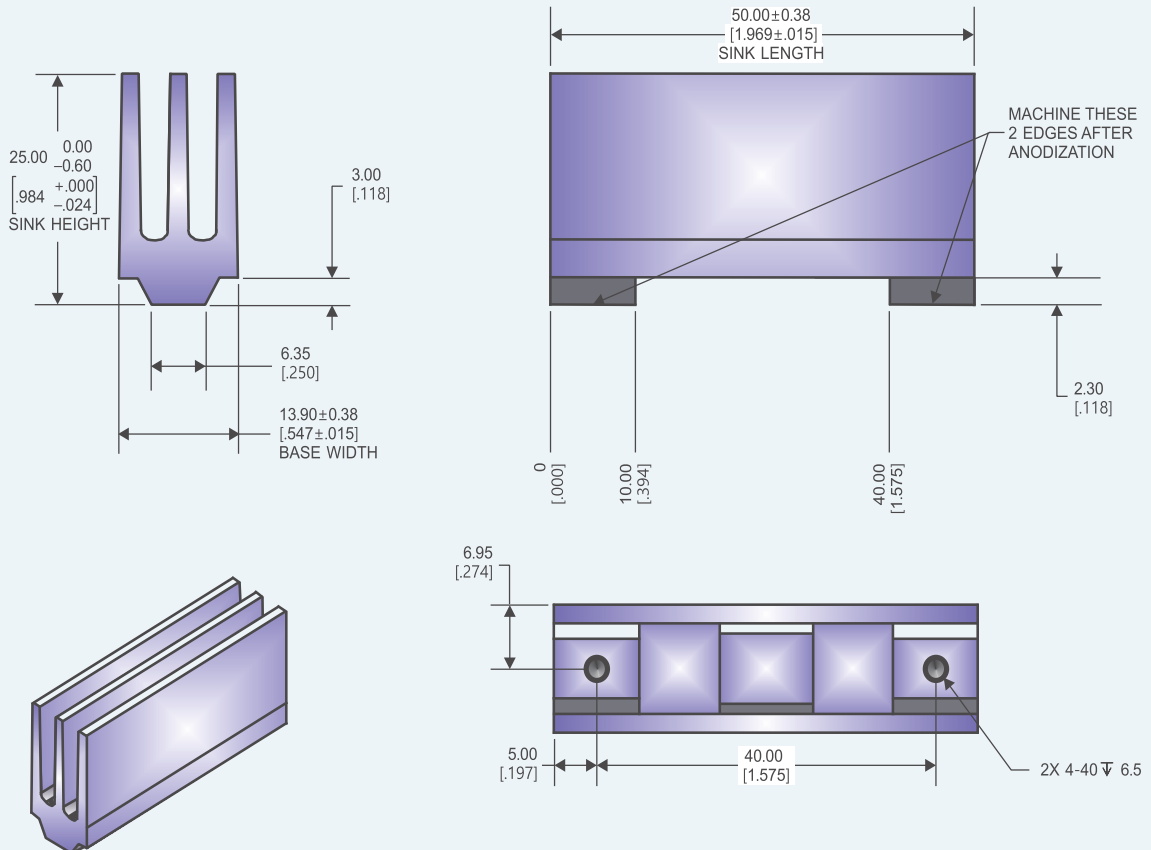

**Package Information**

CS8683H EQB32 (170x150)Package Outline Dimensions units:mm

