

5V USB Input, 1.5A with NTC and Cell Balance, Two Lithium Booster Charging Management IC

General Description

CS5086E is a 5V input, with a maximum charging current of 1.5A. It supports the boost charging management IC of two lithium-ion batteries. CS5086E integrates power MOS and adopts asynchronous switch architecture, so that it only needs a few peripheral devices in its application, which can effectively reduce the overall scheme size and BOM cost. The boost switch charging converter of CS5086E has a working frequency of 500KHz and a conversion efficiency of 90%. The input voltage of CS5086E is 5V, with built-in adaptive loop, which can intelligently adjust the charging current, prevent the output of the adapter from being pulled out, and match all adapters. CS5086E has the function of battery cell balance, which can effectively extend the life of battery pack. The balance current can be adjusted by external resistance.

Features

- USB 5V Input Asynchronous Switch Boost Charging
- 90% Boost Charge Efficiency
- Working Voltage 3.5 ~ 6V, Chip Withstand Voltage 18V, Internal Integrated High Voltage Transistor
- Up to 1.5A Charging Current, External Resistance of Charging Current Adjustable
- NTC Function
- Automatically Adjust Input Current to Match All Adapters
- Automatic battery cell balance, which can charge the series battery separately
- Support LED Charging Status Indication
- Built in Power MOS
- 500KHz Switching Frequency
- Battery SCP and OVP Protection
- Input Voltage UVLO and OVP Protection
- IC Over Temperature Protection
- ESD 4KV

Package

- ESOP10L
- DFN3X3_10L

Applications

- Bluetooth Speakers
- POS Machine
- E-Cigarette
- Lithium Battery Pack
- handheld transceiver
- Toys

Typical Applications

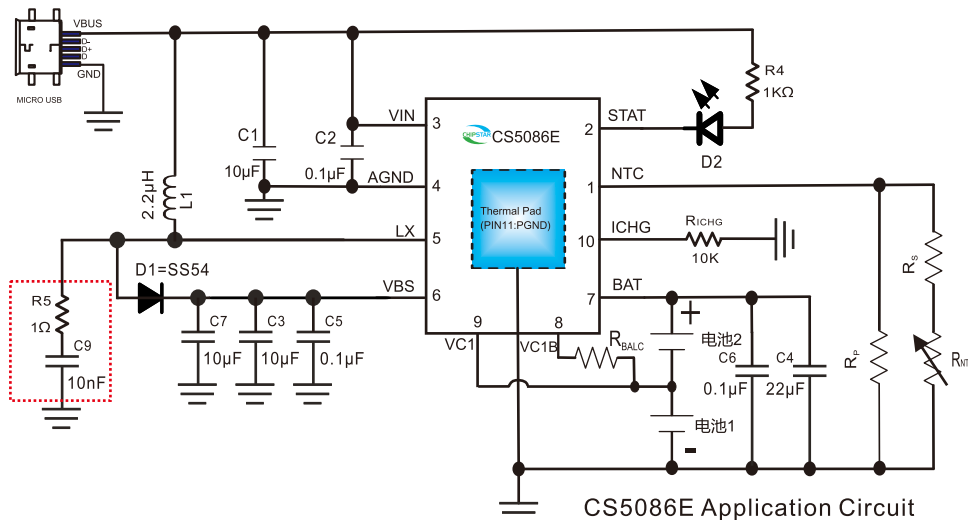

Note:

- (1) L1 is a power inductor with a saturation current of 5A, and SS54 is a low-voltage drop Schottky diode.
- (2) All chip capacitors need to be as close to the chip pin layout as possible.
- (3) If the NTC function is not used, pin 1 of the chip, which is the NTC pin, can be left floating directly.
- (4) If the balancing function is not used, the two pins VC1 and VC1B can be left floating directly.
- (5) The setting value of constant current charging current must be greater than 500mA, that is, R_{ICHG} must be less than 20KΩ.
- (6) When hot plug operation is required at the battery end, or inductive load such as motor is connected, it is suggested to add another capacitor of at least 100μF beside C4 to further improve reliability.
- (7) The Pin 2 of the chip, namely the STAT pin, is an output pin of open drain OD structure, which outputs 0 level or high resistance state. If this pin is not used at all, it is recommended to be grounded.
- (8) It is recommended to add a 1KΩ resistor to the ground at the pin 3 of the chip to eliminate the phenomenon that the voltage at the pin 3 may not be 0 when the input power is unplugged due to the reverse leakage current of the Schottky diode itself.
- (9) When aiming to improve EMI performance, it is necessary to add an absorption network composed of R5 and C9.
- (10) The solid red line in the figure shows the path of high current flow.

PIN Configuration and Functions

ESOP10L CS5086E

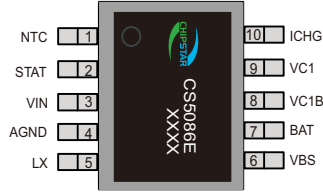

DFN3X3_10L CS5086D

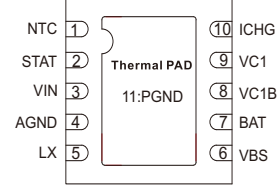

CS5086E PIN	NAME	TYPE	DESCRIPTION
1	NTC	I	Thermistor input pin, through the external thermistor to detect the battery temperature
2	STAT	O	Charge status indication pin.
3	VIN	P	Analog power input pin.
4	AGND	-	Analog ground pin.
5	LX	I	Switch node pin, connect to external inductor.
6	VBS	P	Boost output pin.
7	BAT	P	Battery positive pin.
8	VC1B	O	Battery balance control output
9	VC1	I	Bottom battery power detection terminal
10	ICHG	O	Charge current program pin, pull down to AGND with a resistor can change the value of charging current.
Thermal PAD	PGND	-	Power ground pin.

Functional Block Diagram

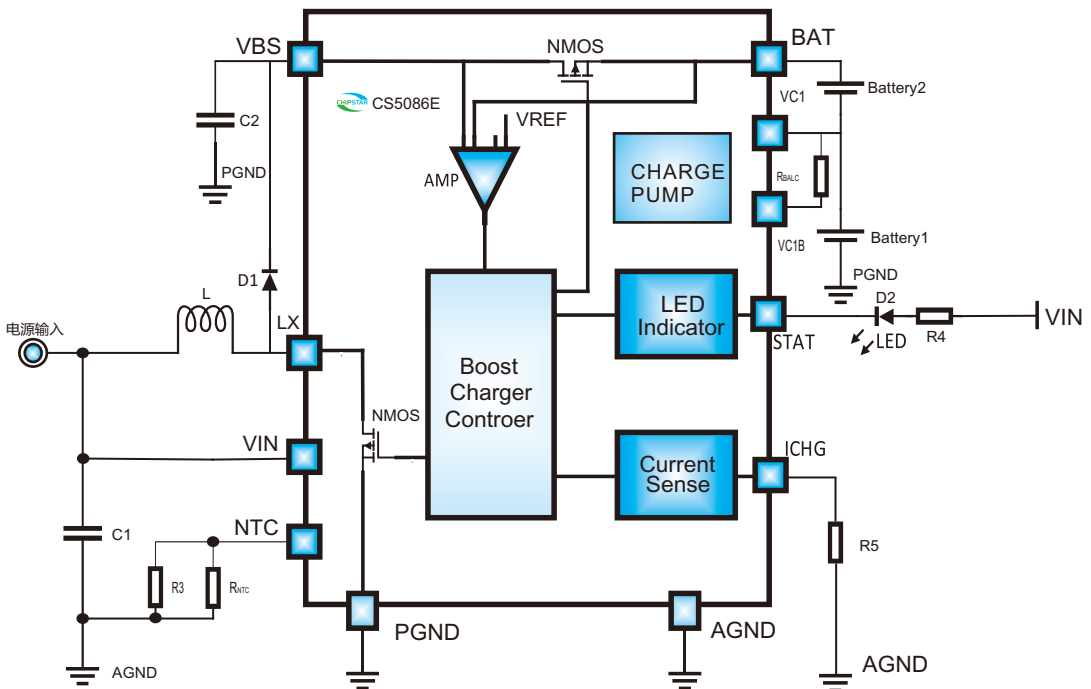

Absolute Maximum Ratings ¹

SYMBOL	PARAMETER	VALUE	UNIT
V _{IN}	Input voltage	-0.3~20	V
T _J	Junction operating temperature range	-40~150	°C
T _{STG}	Storage temperature range	-60~150	°C
T _{SDR}	Lead temperature (Soldering, 10 sec.)	260	°C

Recommended Operating Conditions

SYMBOL	PARAMETER	VALUE	UNIT
V _{IN}	Input voltage	3.5~6	V
T _J	Junction operating temperature range	-40~125	°C
T _A	Ambient temperature range	-40~85	°C

Thermal Information ²

SYMBOL	PARAMETER	VALUE	UNIT
θ _{JA} (ESOP10)	Package thermal resistance - chip to environment thermal resistance	40	°C/W

Ordering Information

Product Name	Package Type	Device Marking	Packing Types	Quantity
CS5086E	ESOP-10L		Tube	100

ESD Range

HBM (Human Body Model) ----- ±4kV
MM (Machine model) ----- ±400V

1. The above parameters are only the limit values of device operation. It is not recommended that the working conditions of the device exceed the limit values. Otherwise, the reliability and life of the device will be affected, and even permanent damage will be caused.

2. Where the PCB board is placed in CS5086E, a heat dissipation design is needed. The heat sink at the bottom of CS5086E is connected with the heat sink area of PCB board.

Electrical Characteristics ($V_{IN}=5V$, $R_{ICHG}=10K\Omega$, $L=2.2\mu H$, unless otherwise specified)

SYMBOL	PARAMETER	TEST CONDITIONS	MIN	TYP	MAX	UNIT
V_{IN}	Supply voltage		3.5		6	V
V_{INUVLO}	VIN under voltage lockout threshold	VIN falling		3.6		V
ΔV_{INUVLO}	VIN under voltage lockout hysteresis			150		mV
V_{INOVLP}	VIN over voltage protection	VIN rising		6		V
ΔV_{INOVLP}	VIN over voltage protection hysteresis			200		mV
I_Q	Input quiescent current			1		mA
I_{BAT}	Battery leakage current	Charging complete		200		μA
		$V_{IN}=0V$		10		
V_{CV}	Terminal battery voltage		8.36	8.40	8.44	V
ΔV_{RCH}	Recharge voltage			200		mV
V_{TRK}	TC charge mode battery voltage threshold			5.6		V
V_{SHORT}	Battery short threshold			2		V
V_{OVLPB}	BAT over voltage threshold			9.1		V
F_{SW}	Switching frequency			500		KHz
V_{TRON}	Block Power MOS full on $V_{TRON}=V_{BAT}-V_{IN}$	$V_{BAT}>V_{TRK}$		150		mV
R_{NFET}	$R_{DS(ON)}$ of Main N-FET			70		$m\Omega$
R_{PFET}	$R_{DS(ON)}$ of Blocking N-FET			70		$m\Omega$
I_{CC}	CC charge mode current	$R_{ICHG}=10K, V_{IN}=5V$		1	1.5	A
I_{TC}	TC charge mode current			120		mA
I_{BS}	Output short circuit charge mode current			75		mA
I_{TERM}	Terminate charge current			100		mA
A_I	CC charge mode current gain	$A_I=I_{CC}/I_{ICHG}$		10000		
V_{ICHG}	ICHG voltage in CC mode			1		V

Electrical Characteristics ($V_{IN}=5V$, $R_{ICHG}=10K\Omega$, $L=2.2\mu H$, unless otherwise specified)

SYMBOL	PARAMETER	TEST CONDITIONS	MIN	TYP	MAX	UNIT
R_{BHS}	Integrated top balance resistor			6		Ω
R_{BLS}	Integrated bottom balance resistor			6		Ω
V_{CBST}	Bottom battery balance enable voltage			3.6		V
V_{CTST}	Top battery balance enable voltage			7.2		V
V_{BB}	Battery damage detection voltage	Difference between two batteries		500		mV
ΔV_{BB}	Battery damage detection hysteresis			200		mV
V_{CELL}	Battery balance threshold	Difference between two batteries		60		mV
ΔV_{CELL}	Battery balance hysteresis			60		mV
I_{NTC}	NTC PIN output current		18	20	22	μA
V_{NTCL}	NTC low temp threshold	V_{NTC} rising		1.44		V
V_{NTCH}	NTC high temp threshold	V_{NTC} falling		0.38		V
V_{NTCF}	Disable NTC function			> 3		V
T_{SD}	Thermal shutdown temperature			140		$^{\circ}C$
ΔT	Thermal shutdown temperature hysteresis			30		$^{\circ}C$
TMR_{TC}	Trick charge time limit			12		Hour
$TMR_{CC/CV}$	CC/CV charge time limit			20		Hour

Typical Characteristics ($T_A = 25^\circ\text{C}$, unless otherwise noted)

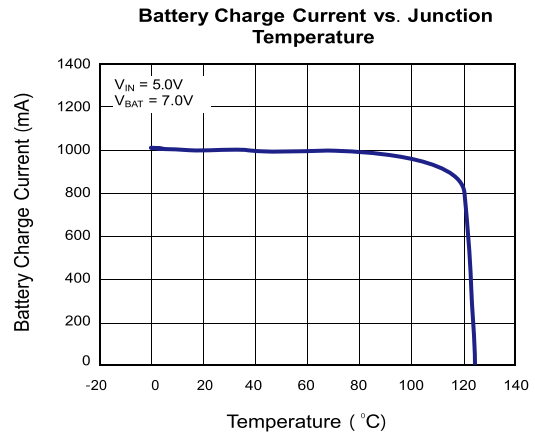
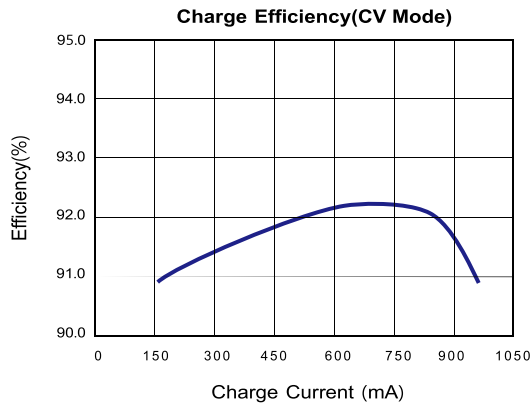
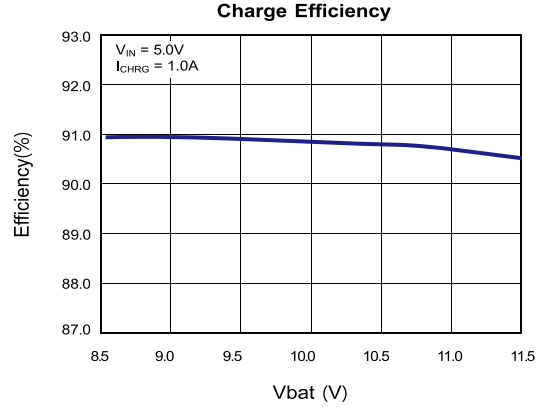
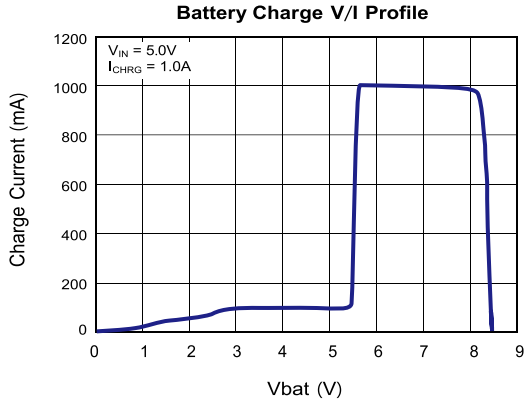

CS5095E Application Points

Overview

CS5086E is a 5V input, integrated high-voltage device inside the chip, which can withstand 18V spike at most, supports 1.5A charging current at most, and two lithium battery charging asynchronous boost charging controller. The working frequency of the boost switch charging converter is 500KHz, and it has perfect charging protection function. Internal integration of automatic power balance function, can effectively improve the battery pack life. The chip can easily adjust the resistance of the external resistance to change the charging current. For different kinds of adapters, the chip has built-in adaptive current regulation loop to intelligently adjust the charging current, so as to prevent the adapter from being pulled out due to the excessive charging current. The power MOS is built into the chip to realize less peripheral devices and save system cost.

Charge Process

CS5086E adopts complete CC/CV charging mode. When the battery voltage is less than 2V, the system charges the batteries with $1/20 I_{CC}$. When the voltage of three lithium batteries is more than 3V but less than 5.6V, the system charges the batteries with $1/10 I_{CC}$. When the voltage of three lithium batteries is greater than 5.6V, the system enters into constant current charging mode. When the battery voltage is close to 8.4V, the system enters constant voltage mode. After entering the constant voltage mode, if the charging current is less than 100mA, the system will stop charging. When the battery is full, if the battery voltage drops below 8.2V again, the system will restart to charge the battery.

Protection Function

CS5086E has perfect battery charging protection function. When the chip appears input over-voltage, output over-voltage and over temperature, boost charging function will be closed immediately. When the battery voltage is lower than V_{SHORT} , the output undervoltage protection function is turned on, the main power tube is turned off first, the Block MOS will enter the linear mode, and charge the battery with $1/20 I_{CC}$ charging current; when the battery voltage is higher than V_{SHORT} , the output short-circuit protection function is turned off.

Adaptive Input Current Limit Function

CS5086E is equipped with a special loop, which can automatically adjust the charging current to protect the input DC power into the overdrive state. Because the large charging current will lead to the drop of input power supply voltage. With the decrease of the power supply voltage, the input of the internal adaptive loop operational amplifier also drops. When the internal reference value is reduced, the built-in adaptive loop will automatically adjust the duty cycle of the system, so as to reduce the charging current, thus reducing the driving pressure of the input power supply, so that the output voltage is fixed at 4.5V.

LED Indicator

- The charging process is always on, and it will be extinguished when fully charged.
- In case of input over voltage, battery over voltage, abnormal battery temperature detected by NTC port, battery short circuit, charging time timeout, chip over temperature, flicker at the frequency of 1.6Hz.

NTC Resistance Setting

CS5086E supports NTC protection function when the battery is charging, through NTC pin check the temperature of the battery, and its specific application is shown in the figure below. When the detection temperature exceeds the set window value, the system will stop charging.

If NTC function is not needed, float the pin or connect it to high level higher than 3V.

The operation mode of this function is to output a constant $20\mu A$ current from NTC pin, and the external resistance on NTC is connected to GND. The temperature range of the battery is determined by the voltage drop generated by the current on the resistance. The internal low temperature judgment point is 1.44V, and the high temperature judgment point is 0.38V. The following values can be used for reference: $R_{NTC}=100K\Omega$ thermistor (B=4000), $R_p=82K\Omega$, corresponding temperature and NTC terminal voltage are as follows:

Temperature(°C)	Voltage(V)
-10	1.44
60	0.38

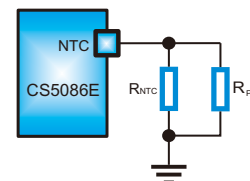

If other high and low temperature protection points need to be designed, as shown in the figure, resistance network composed of R_p and R_s can be used to design with appropriate NTC resistance.

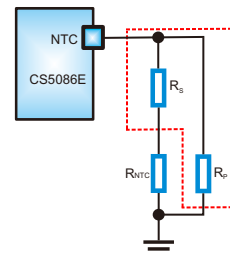

ICHG Resistor R_{ICHG}

The value of the resistance at the end of the ICHG reflects the charging current. According to different applications, it is convenient to adjust the resistance value of the resistance at the end of the ICHG R_{CS} to determine the charging current. The specific circuit is shown in the figure below:

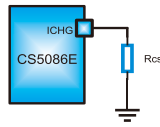

The relationship between I_{CC} , R_{ICHG} in CC charging mode is determined by the following equation:

$$I_{CC} = \frac{1 * 10000}{R_{CS}}$$

Selection of Inductance

The following factors shall be considered when selecting inductive type:

- Determine the ripple current of the inductance. Generally, the recommended ripple current of inductance is 40% of the average current of inductance, and its calculation formula is as follows:

$$L = \left(\frac{V_{IN}}{V_{OUT}} \right)^2 * \frac{V_{OUT} - V_{IN}}{I_{CC} * F_{SW} * 40\%}$$

F_{SW} is the switching frequency, and the charging current set by I_{CC} is quite adaptable to different ripple amplitudes, so even if the value of the final inductance deviates slightly from the calculated value, it will not affect the overall performance of the system.

- The saturation current of the selected inductor must be greater than the peak current of the inductor when the system is working in the full load range.

$$I_{SAT.MIN} > \frac{V_{OUT}}{V_{IN}} * I_{CC} + \left(\frac{V_{IN}}{V_{OUT}} \right)^2 * \frac{V_{OUT} - V_{IN}}{2 * F_{SW} * L}$$

- The DCR and core loss of the inductor must be as low as possible to obtain better system efficiency.
- We recommend the use of CD54 power inductor with an inductance of 2.2μH and a saturation current of 3.5A.

Battery Cell Balance Function

CS5086E has built-in two battery charging cell balance function, which is realized by detecting the voltage difference between two batteries ($V_{CELL} = \pm (V_{CELL1} - V_{CELL2})$), and its specific application is shown in the figure below.

The balance function is enabled by two port voltages of VC1 and VBAT. Only when the two conditions of VC1 greater than 3.6V and VBAT greater than 7.2V are met at the same time, the balance module can be enabled normally. When V_{CELL} is greater than 60mV, the chip starts the balance function until V_{CELL} becomes 0mV. When V_{CELL} is greater than 500mV, the chip will stop charging the battery if it is judged that the battery is damaged, and continue to resume charging until V_{CELL} is less than 300mV.

When the balance function is started, the balance current is calculated by connecting the series resistance to VC1B, and the calculation formula is as follows (the value of R_{BALC} must be greater than 15Ω):

$$I_{BHS} = V_{CELL2} / (6 + R_{BALC})$$

$$I_{BLS} = V_{CELL1} / (6 + R_{BALC})$$

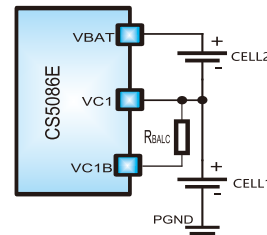

Battery balance scheme

Note: If balance function is not used, VC1 and VC1B can be suspended.

Large Current Expansion Scheme of Electric Quantity Balance

The maximum balance current capacity of the built-in power balance module of CS5086E is 200mA. If more balance current is needed, please expand the current capacity according to the scheme shown in the figure below. In the figure, R_b is the base current limiting resistance of external triode, and R_{BALC} is the current control resistance of electric quantity balance.

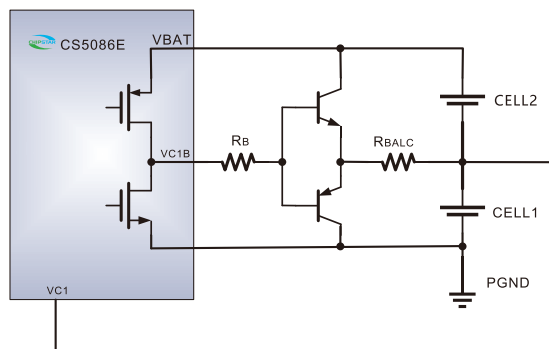

Large current expansion scheme of electric quantity balance

CS5086E Charging Module Circuit, BOM and PCB

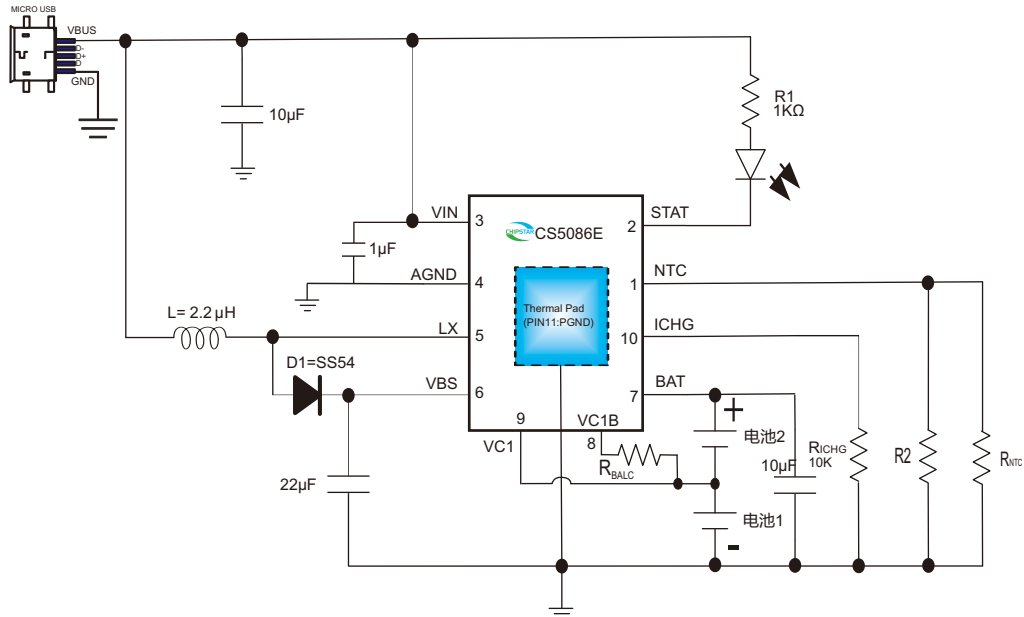

CS5086E Application Circuit

BOM

NO.	Device Name	Specifications	Unit	Quantity	Position	Remarks
1	IC	CS5086E	PCS	1	U1	
2	SMD res.	0805 1KΩ 5%	PCS	1	R1	Adjust the LED brightness
3	SMD res.	0603	PCS	1	R _p	Add R _p according to the temperature point
4	SMD res.	NTC Resistance	PCS	1	R _{NTC}	NTC pin partial resistance
5	SMD res.	0603 10kΩ 1%	PCS	1	R _{ICHG}	Adjust charge current
6	SMD res.	0603 1kΩ 5%	PCS	1	R _{BALC}	Adjust balance charge current
7	SMD cap.	0805 22µF@X5R 16V	PCS	2	C3	
8	SMD cap.	0603 10µF@X5R 16V	PCS	1	C1, C4	
9	SMD cap.	0805 1µF@X5R 16V	PCS	1	C2	
10	SMD LED	0603	PCS	1	D2	
11	SMD diode.	SS54	PCS	1	D1	Schottky diode
12	Inductor	CD54	PCS	1	L1	SWPA5040 L=2.2uH

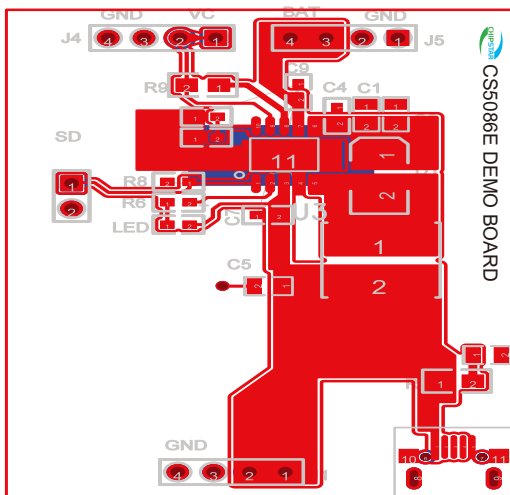

CS5086E PCB Precautions

- The power supply wiring shall be as wide as possible, and the CS5086E shall be powered separately from the power supply wiring.
- The main current circuit of boost module should be short and thick.
- LX runs as short as possible to reduce EMI.
- Inductors and Schottky's should be connected directly. The connection should be short and thick, avoiding through hole jumper.
- The capacitance at the power supply end should be placed as close to the chip as possible.
- The bottom heat sink of the chip is power ground and should be connected to a large area. The bottom heat sink must be reliably welded to the ground.

Package information CS5086E ESOP10L PACKAGE INFORMATION

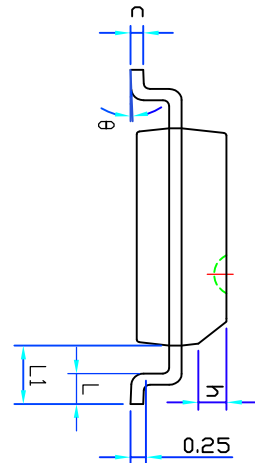
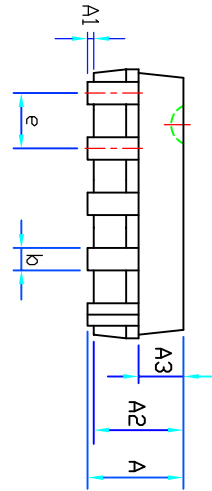
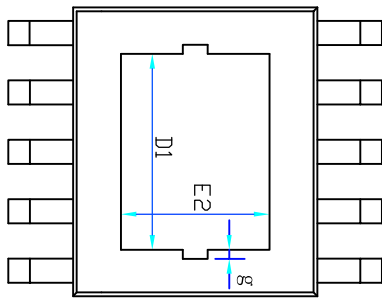
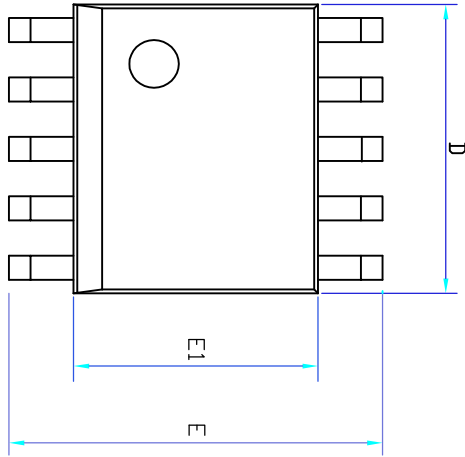

SYMBOL	MILLMETER		
	MIN	NOM	MAX
A	—	—	1.50
A1	0.02	0.05	0.08
A2	1.30	1.40	1.50
A3	0.70	0.75	0.80
b	0.35	—	0.45
c	0.20	—	0.24
D	4.80	4.90	5.00
D1	3.10REF		
e	1.00BSC		
E	6.05	6.15	6.25
E1	3.82	3.92	4.02
E2	2.20REF		
L	0.50	—	0.70
L1	1.15REF		
h	0.30	0.40	0.50
θ	0	—	8°
g	0.15REF		

Package information

CS5086D PACKAGE INFORMATION

DFNWB3X3_10L(P0.5T0.5/0.85) PACKAGE OUTLINE DIMENSIONS

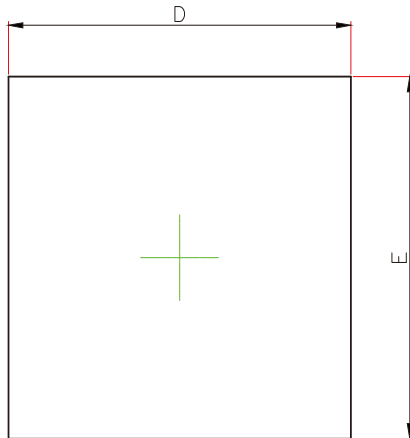

TOP VIEW

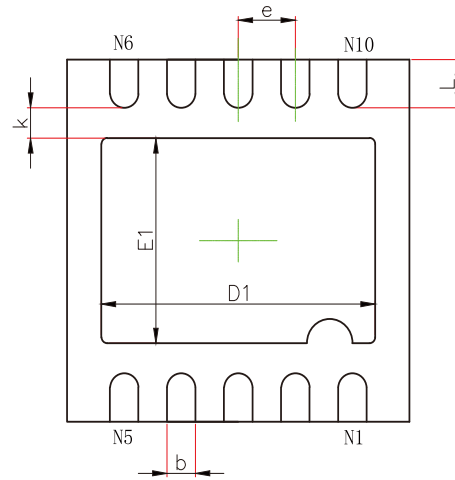

BOTTOM VIEW

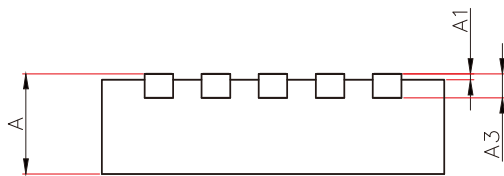

SIDE VIEW

Symbol	Dimensions In Millimeters		Dimensions In Inches	
	Min.	Max.	Min.	Max.
A	0.700/0.800	0.800/0.900	0.028/0.031	0.031/0.035
A1	0.000	0.050	0.000	0.002
A3	0.203REF.		0.008REF.	
D	2.924	3.076	0.115	0.121
E	2.924	3.076	0.115	0.121
D1	2.300	2.500	0.091	0.098
E1	1.600	1.800	0.063	0.071
k	0.200MIN.		0.008MIN.	
b	0.200	0.300	0.008	0.012
e	0.500TYP.		0.020TYP.	
L	0.324	0.476	0.013	0.019