

5 Ω, Low Voltage SPDT Analog Switch in 6-Pin SC70

General Description

The CS3157S is a bidirectional, SPDT (single-pole/double-throw), CMOS analog switch. It operates from a 1.8V to 5.5V single power supply. The CS3157S features low on-resistance, low voltage and high bandwidth. The high performances make it very suitable for multiple applications, such as portable equipment, audio and video signal routing, etc. Low power consumption is also one of the important reasons that make it a good choice.

The CS3157S is available in a Green SC70-6 package. It operates over an ambient temperature range of -40°C to +85°C.

Features

- Single Supply Voltage Range: 1.8V to 5.5V
- Low On-Resistance: 5Ω (TYP) at $V_+ = 4.5V$
- Fast Switching Times:
 t_{ON} : 20ns (TYP)
 t_{OFF} : 15ns (TYP)
- Low On-Resistance Flatness
- -3dB Bandwidth: 300MHz
- High Off-Isolation: -51dB at 10MHz

Applications

- TV Board
- Portable Equipment
- Personal Digital Assistants
- Battery-Powered Systems

Package

- SC70-6

Pinout (Top view)

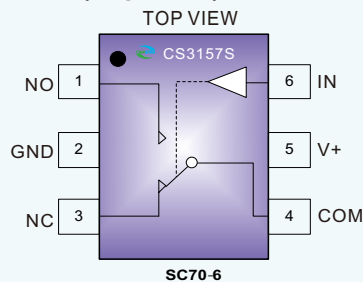

PIN DESCRIPTION

PIN	NAME	FUNCTION
1	NO	Normally Open Pin.
2	GND	Ground .
3	NC	Normally Closed Pin.
4	COM	Common Pin.
5	V+	Positive Power Supply Pin.
6	IN	Digital Control Pin to Connect the COM Pin to the NO or NC Pin.

TEST CIRCUITS

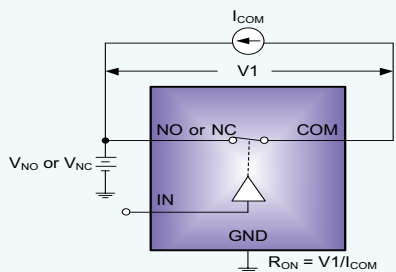

Test Circuit 1. On-Resistance

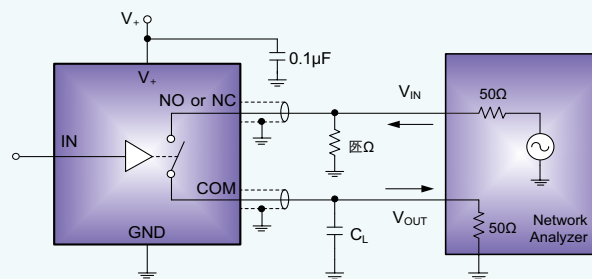

Test Circuit 2. Off Isolation

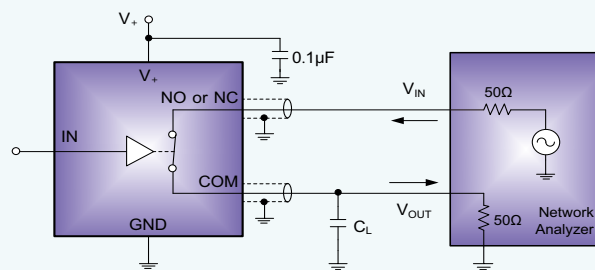

Test Circuit 3. -3dB Bandwidth

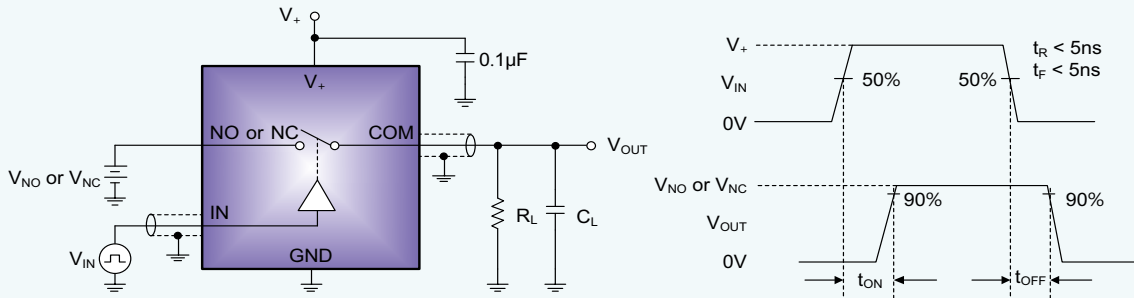

Test Circuit 4. Switching Times

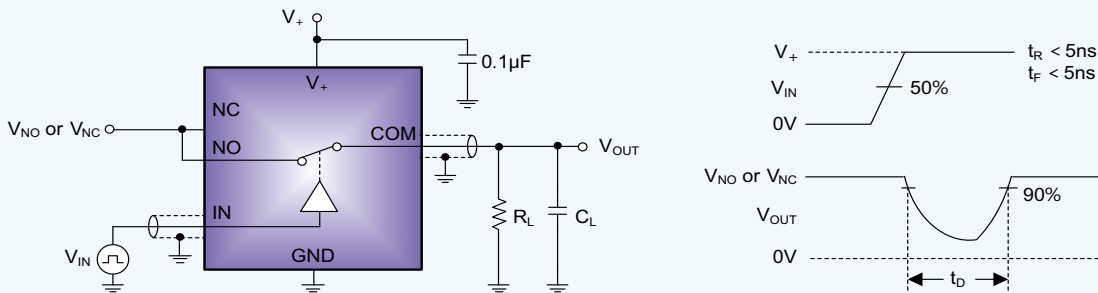

Test Circuit 5. Break-Before-Make Time Delay (t_D)

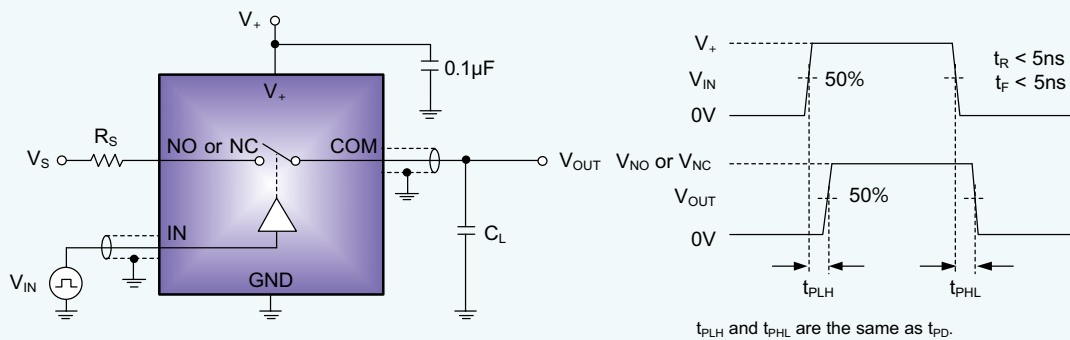

Test Circuit 6. Propagation Delay Time (t_{PD})

Absolute Maximum Ratings

V+, IN to GND	-----	-0.3V to 6.0V
Analog, Digital Voltage Range	-----	-0.3V to (V+) + 0.3V
Continuous Current NO, NC, or COM	-----	±50mA
Peak Current NO, NC, or COM	-----	±80mA
θ_{JA}	-----	180°C/W
θ_{JC}	-----	90°C/W
Junction Temperature	-----	150°C
Lead Temperature (Soldering, 10 sec.)	-----	260°C
Storage Temperature Range	-----	-65°C to 150°C
Junction Temperature Range	-----	-40°C to 125°C
Ambient Temperature Range	-----	-40°C to 85°C
ESD HBM(Human Body Mode)	-----	4KV
ESD MM(Machine Mode)	-----	400V

Recommended Operating Conditions

Ambient Temperature Range	-----	-40°C to 85°C
---------------------------	-------	---------------

Order Information

Device	Package	Making	Reel Size	Tape Width	Quantity
CS3157S	SC70-6		7"	8mm	3000

Electrical Characteristics (V₊=4.5V to 5.5V, Full = -40°C to 85°C, typical values are at V₊ = 5.0V, TA = 25°C, unless otherwise noted.)

PARAMETER	SYMBOL	CONDITIONS	TEMP	MIN	TYP	MAX	UNITS
ANALOG SWITCH							
Analog Signal Range	V _{NO} , V _{NC} , V _{COM}		Full	0		V ₊	V
On-Resistance	R _{ON}	V ₊ = 4.5V, V _{NO} or V _{NC} = 0V to 4.5V, I _{COM} = -10mA, Test Circuit 1	+25°C		5	7.5	Ω
			Full			8.5	Ω
On-Resistance Match Between Channels	ΔR _{ON}	V ₊ = 4.5V, V _{NO} or V _{NC} = 0V to 4.5V, I _{COM} = -10mA, Test Circuit 1	+25°C		0.3	0.7	Ω
			Full			0.8	Ω
On-Resistance Flatness	R _{FLAT(ON)}	V ₊ = 4.5V, V _{NO} or V _{NC} = 0V to 4.5V, I _{COM} = -10mA, Test Circuit 1	+25°C		2.3	3.3	Ω
			Full			4.5	Ω
Source Off Leakage Current	I _{NC(OFF)} , I _{NO(OFF)}	V ₊ = 5.5V, V _{NO} or V _{NC} = 1.0V, 4.5V, V _{COM} = 4.5V, 1.0V	Full			1	μA
Channel On Leakage Current	I _{NC(ON)} , I _{NO(ON)} , I _{COM(ON)}	V ₊ = 5.5V, V _{COM} = 1.0V, 4.5V, V _{NO} or V _{NC} = 1.0V, 4.5V, or floating	Full			1	μA
DIGITAL INPUTS							
Input High Voltage	V _{INH}	V ₊ = 4.5V	Full	1.8			V
Input Low Voltage	V _{INL}	V ₊ = 4.5V	Full			0.4	V
Input Leakage Current	I _{IN}	V ₊ = 5.5V, V _{IN} = 0V or 5.5V	Full			1	μA
DYNAMIC CHARACTERISTICS							
Turn-On Time	t _{ON}	V _{NO} or V _{NC} = 3V, R _L = 300Ω, C _L = 35pF, Test Circuit 2	+25°C		20		ns
Turn-Off Time	t _{OFF}	V _{NO} or V _{NC} = 3V, R _L = 300Ω, C _L = 35pF, Test Circuit 2	+25°C		15		ns
Break-Before-Make Time Delay	t _D	V _{NO} = V _{NC} = 3V, R _L = 300Ω, C _L = 35pF, Test Circuit 3	+25°C		5		ns
Propagation Delay Time (Signal Input to Output)	t _{PD}	R _S = 39Ω, C _L = 50pF, Test Circuit 4	+25°C		5		ns
Off Isolation	O _{ISO}	R _L = 50Ω, C _L = 5pF, Signal = 0dBm, Test Circuit 5	f = 10MHz	+25°C		-51	dB
			f = 1MHz	+25°C		-72	dB
-3dB Bandwidth	BW	Signal = 0dBm, R _L = 50Ω, C _L = 5pF, Test Circuit 6	+25°C		300		MHz
Source Off Capacitance	C _{NC(OFF)} , C _{NO(OFF)}	f = 1MHz	+25°C		5.5		pF
Channel On Capacitance	C _{NC(ON)} , C _{NO(ON)} , C _{COM(ON)}	f = 1MHz	+25°C		15.5		pF
POWER REQUIREMENTS							
Power Supply Range	V ₊		Full	1.8		5.5	V
Power Supply Current	I ₊	V ₊ = 5.5V, V _{IN} = 0V or V ₊	Full			5	μA
ANALOG SWITCH							
Analog Signal Range	V _{NO} , V _{NC} , V _{COM}		Full	0		V ₊	V
On-Resistance	R _{ON}	V ₊ = 2.7V, V _{NO} or V _{NC} = 0V to 2.7V, I _{COM} = -10mA, Test Circuit 1	+25°C		14	19	Ω
			Full			21	Ω
On-Resistance Match Between Channels	ΔR _{ON}	V ₊ = 2.7V, V _{NO} or V _{NC} = 0V to 2.7V, I _{COM} = -10mA, Test Circuit 1	+25°C		0.3	1	Ω
			Full			1.2	Ω
On-Resistance Flatness	R _{FLAT(ON)}	V ₊ = 2.7V, V _{NO} or V _{NC} = 0V to 2.7V, I _{COM} = -10mA, Test Circuit 1	+25°C		9	14	Ω
			Full			15	Ω
Source Off Leakage Current	I _{NC(OFF)} , I _{NO(OFF)}	V ₊ = 3.6V, V _{NO} or V _{NC} = 0.3V, 3.3V, V _{COM} = 3.3V, 0.3V,	Full			1	μA
Channel On Leakage Current	I _{NC(ON)} , I _{NO(ON)} , I _{COM(ON)}	V ₊ = 3.6V, V _{COM} = 0.3V, 3.3V, V _{NO} or V _{NC} = 0.3V, 3.3V, or floating	Full			1	μA
DIGITAL INPUTS							
Input High Voltage	V _{INH}	V ₊ = 2.7V	Full	1.5			V
Input Low Voltage	V _{INL}	V ₊ = 2.7V	Full			0.3	V
Input Leakage Current	I _{IN}	V ₊ = 3.6V, V _{IN} = 0V or 3.6V	Full			1	μA

Electrical Characteristics ($V_+ = 2.7V$ to $3.6V$, Full = $-40^\circ C$ to $85^\circ C$, typical values are at $V_+ = 3.0V$, $T_A = 25^\circ C$, unless otherwise noted.)

PARAMETER	SYMBOL	CONDITIONS	TEMP	MIN	TYP	MAX	UNITS
DYNAMIC CHARACTERISTICS							
Turn-On Time	t_{ON}	V_{NO} or $V_{NC} = 1.5V$, $R_L = 300\Omega$, $C_L = 35pF$, Test Circuit 2	$+25^\circ C$		30		ns
Turn-Off Time	t_{OFF}	V_{NO} or $V_{NC} = 1.5V$, $R_L = 300\Omega$, $C_L = 35pF$, Test Circuit 2	$+25^\circ C$		25		ns
Break-Before-Make Time Delay	t_D	$V_{NC} = V_{NO} = 1.5V$, $R_L = 300\Omega$, $C_L = 35pF$, Test Circuit 3	$+25^\circ C$		8		ns
Propagation Delay Time (Signal Input to Output)	t_{PD}	$R_S = 39\Omega$, $C_L = 50pF$, Test Circuit 4	$+25^\circ C$		2		ns
Off Isolation	O _{ISO}	$R_L = 50\Omega$, $C_L = 5pF$, Signal = 0dBm, Test Circuit 5	$f = 10MHz$	$+25^\circ C$	-51		dB
			$f = 1MHz$	$+25^\circ C$	-72		dB
-3dB Bandwidth	BW	Signal = 0dBm, $R_L = 50\Omega$, $C_L = 5pF$, Test Circuit 6	$+25^\circ C$		300		MHz
Source Off Capacitance	$C_{NC(OFF)}$, $C_{NO(OFF)}$	$f = 1MHz$	$+25^\circ C$		5.5		pF
Channel On Capacitance	$C_{NC(ON)}$, $C_{NO(ON)}$, $C_{COM(ON)}$	$f = 1MHz$	$+25^\circ C$		15.5		pF
POWER REQUIREMENTS							
Power Supply Range	V_+		Full	1.8		5.5	V
Power Supply Current	I_+	$V_+ = 3.6V$, $V_{IN} = 0V$ or V_+	Full			5	μA

TYPICAL PERFORMANCE CHARACTERISTICS

On Response vs. Frequency

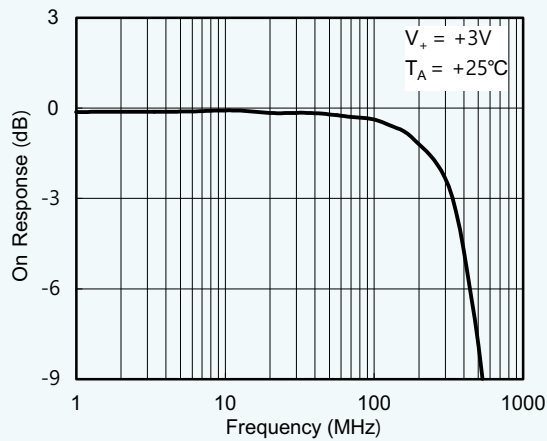

On Response vs. Frequency

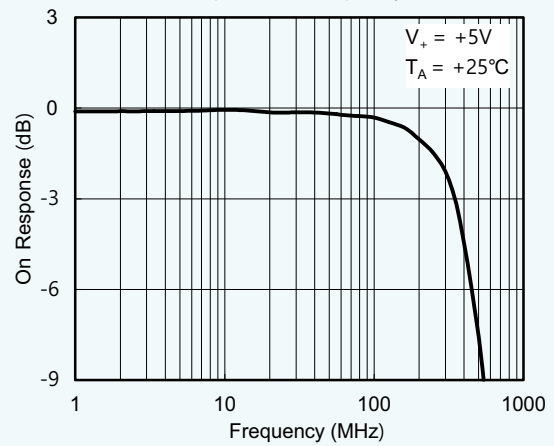

Response vs. Frequency

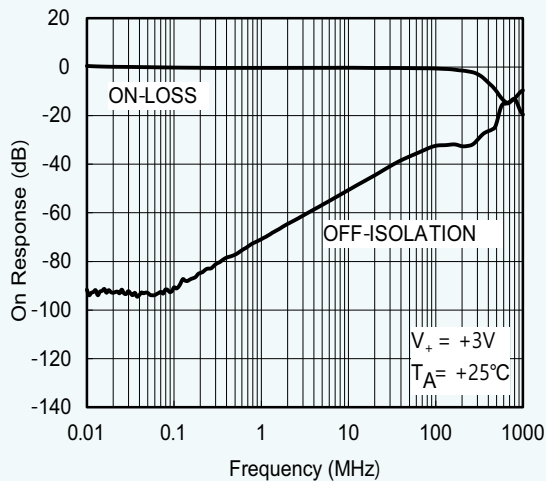

Response vs. Frequency

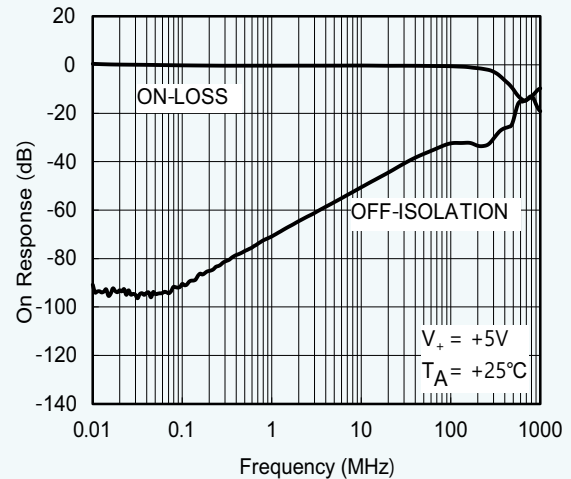

Package Information

CS3157S SC70-6 PACKAGE INFORMATION

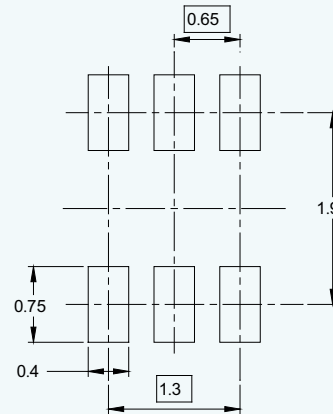
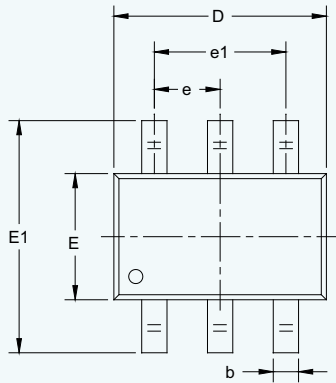

RECOMMENDED LAND PATTERN (Unit: mm)

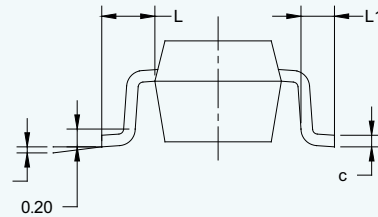
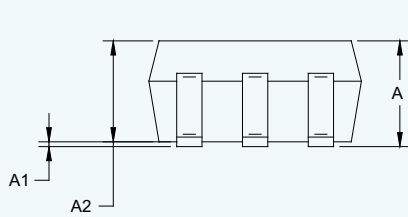

Symbol	Dimensions In Millimeters		Dimensions In Inches	
	MIN	MAX	MIN	MAX
A	0.900	1.100	0.035	0.043
A1	0.000	0.100	0.000	0.004
A2	0.900	1.000	0.035	0.039
b	0.150	0.350	0.006	0.014
c	0.080	0.150	0.003	0.006
D	2.000	2.200	0.079	0.087
E	1.150	1.350	0.045	0.053
E1	2.150	2.450	0.085	0.096
e	0.65 TYP		0.026 TYP	
e1	1.300 BSC		0.051 BSC	
L	0.525 REF		0.021 REF	
L1	0.260	0.460	0.010	0.018
	0°	8°	0°	8°